

**SHORT CIRCUITS** A REGULAR FEATURE OF GRID LEAKS, THIS PAGE PRESENTS SHORT NOTES OF IMPROVEMENTS DEVELOPED BY READERS. SEND US YOUR BRAIN CHILD!

**LORENZ 50 IMPROVEMENT**

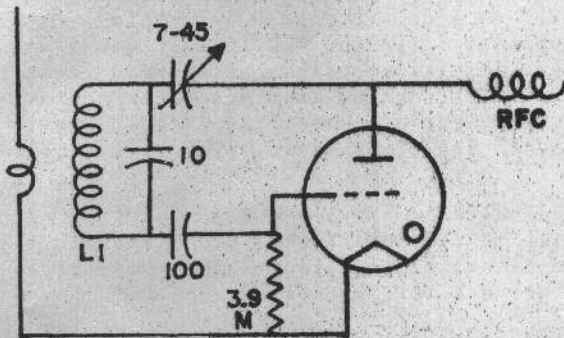

L1--8 turns #20 on 3/8" slug coil form  
L2--60 turns #32 on 1/4" poly form

L. E. Stadler of Roswell, N. M., experienced difficulty with his Lorenz 50 mc two tube receiver. It would not hold second stage down decently. The use of a 7-45 trimmer in place of the customary fixed 47 mmf between tank coil and plate of the RK61 cured it. With a .5 idle on first stage adjust trimmer for 0 on second stage. This may work well on 27 1/2 mc too.

**CUT ACTUATOR DRAIN**

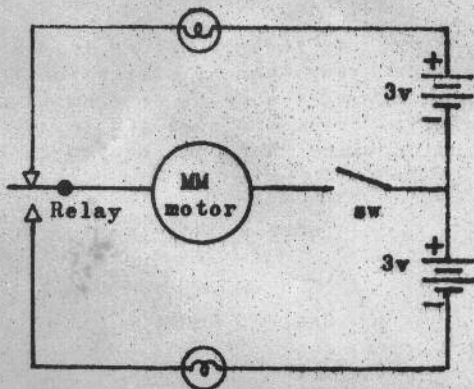

The use of #55 parking light bulbs-6-8 volts-will help cut down the stalled drain of a Mighty Midget when used as an actuator in proportional systems suggests Don Parsons of Mt. Prospect, Ill.

**WAG DUAL BOAT INSTALLATION**

While the WAG Dual TTPW system was developed primarily for aircraft, it did not take long to find an adequate harnessing of the system to boats. From Vestal, N. Y., Bernard Fox reports that boats there of the larger type, such as Sterling's American Scout, are using the system. The rudder channel is used to operate a Robot Synchro in the conventional manner for rudder control. (Ed. Note: This could also be Mighty Midget or other actuator.) The elevator channel is used to operate another Robot Synchro which is hooked up to a pot which is connected as shown in the drawings. This provides proportional control speed in BOTH forward and reverse as well as stop. The fail safe may be utilized for horns, lights, winches or what have you

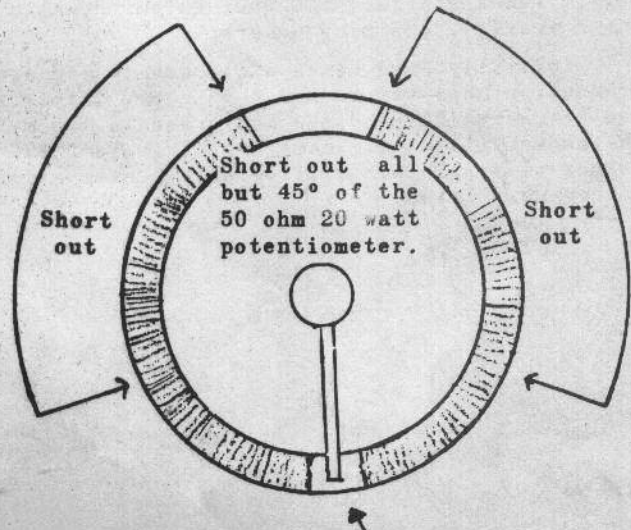
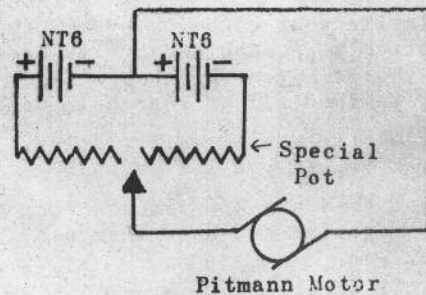

Break wire on pot at this point. Make sufficient space for arm to rest to provide a stop.

# GRID LEAKS

COPYRIGHT 1957



THE MAGAZINE DEVOTED EXCLUSIVELY TO RADIO CONTROL

HIGGINSVILLE, MO.

Dear Subscriber:

Well here it is at last! Somewhat delayed but nevertheless still very much in the running, your charter copy of Grid Leaks comes to you.

In the shake down period from the birth of the idea to the putting into motion of the idea and the final product, there have been a lot of changes. Initially we had felt that it might become a full fledged magazine carrying advertising. This idea was abandoned somewhere along the line when suggestions began coming in that an expanded R/C Technical Data Service would provide a much more needed type of publication in the R/C field. Queries to several parties throughout the country confirmed this initial approach and so Grid Leaks has been expanded into an R/C Data Service. Each issue will bring you from six to ten data ideas containing experimental circuits, installation procedures, as well as circuit shorts and a general editorial letter. For the time being, at least, no advertising will be carried so that the entire content will be editorial.

Grid Leaks will devote itself entirely to technical data and leave the reporting of contest, individual flying comments, and so on, strictly to the established model magazines in the field. By this step we feel that we are not in direct competition to these magazines but offer a supplementary and distinctly different service for the serious R/C fan.

We hope to maintain a very informal tone and present a lot of our data in much the same way the copy is submitted to us rather than beautiful drawings since this is to be as an experimenter's magazine. We hope that by presenting experimental data, R/C can be furthered by encouraging beginners and old timers alike to branch out and become willing to try new things in the hope that eventually this experimentation will lead off to even better R/C.

We invite your circuits, your photographs, your kinks, your comments. We hope to publish a letter page each month with comments from you and want to take this opportunity of thanking those of you who have already written in wishing us good luck on this venture. We are going to need all of your help to make this a top notch publication.

If you have any circuitry or design material you would like to see incorporated in these pages, won't you let us know?

If you have any R/C friends whom you feel need to get this publication why not show them this magazine and have them use the handy subscription blank found on one of the interior pages.

Much is in the works for future issues including "We Experiment With The Tech Two On 27 $\frac{1}{2}$ ", "Transistorized WAG Dual Pulser" (which could be converted to conventional pulser quite easily), and many others.

Initially Grid Leaks will come to you every sixty days. We feel it better to plan the production that way rather than every thirty so that we can assure you of a magazine that has been carefully edited and presents the material correctly. As soon as we grow in stature the subscription will come monthly. Your \$2.00 subscription price entitles you to your ten issues although this will be spread over a longer period of time. Hope to see you in this corner next issue.

Yours sincerely,

Paul F. Runge

# Fast I--Simple, Low Cost R/C Boat

This One'll Go on a Heavy Dew!

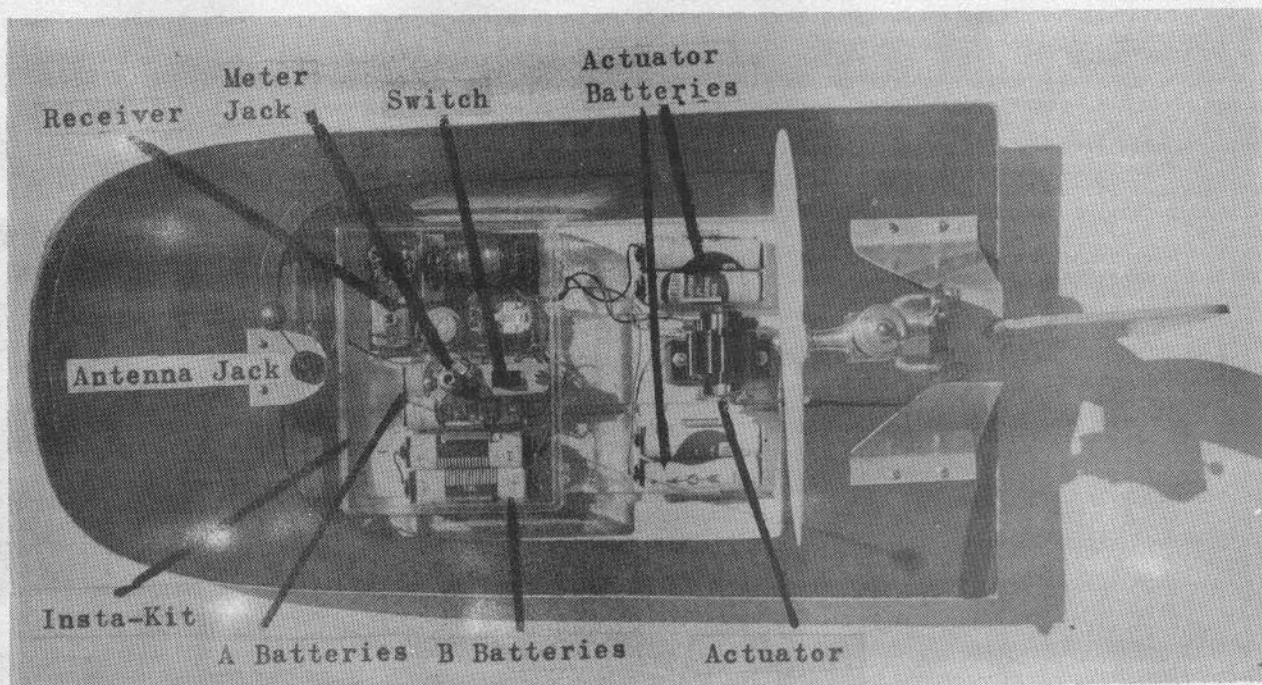

If you have been wanting to get into R/C boating but have held back because electric powered boats move too slowly for your tastes and you felt that power boating was too expensive, Fast I will open your eyes to a whole new world of pleasurable R/C fun.

Much can be said over the advantages of the air driven type of boat for radio control. It does not make near the mess that an inboard does; it is much easier to start; maintenance presents very little problem; fumes are carried away and R/C gear is in no danger of being overcome.

Expense wise, too, it is quite a nice surprise since it doesn't cost nearly what larger and more detailed outfits would. Let's look at the expense for a moment. The Swamp Buggy kit as made by Cava Craft comes beautifully prefabbed with a plastic body and requires only a very little labor to complete. At \$2.95 it is well worth the price. One of the most inexpensive motors is the Cox Babe .049--this with a 6/4 prop will give you ample power; in fact it may give more than you may initially be able to handle. The Commander Receiver will be found to be more than adequate for this installation. We chose pulse and there is no advantage in having a current rise receiver in pulse work, the Commander can be pulsed quite fast and cleanly.

The Insta-Pak was chosen in order to help make the installation neat and also to provide a measure of protection from spray. All batteries are mounted on the inside of the Insta-Pak with the exception of the two sets of actuating batteries. As you can see from the illustration these are mounted on either side of the Mighty Midget motor, which is an excellent device to actuate.

We chose proportional control quite deliberately. Fast I is fast! Servo or escapement type of actuation would have been all or nothing and in our opinion at the speeds that Fast I travels they could quite easily capsize the boat. In proportional you get the degree of control you want in the direction you want and your proportional transmitter will handle this quite nicely. Either a mechanical or an electronic pulser of the WAG type are to be highly recommended.

The expense is very small in comparison to other installations that could be mentioned. We list it here for you:

Swamp Buggy	\$2.95
Cox Babe .049	3.95
Commander Receiver	7.95
Insta-Pak	2.50
Mighty Midget Motor	2.95
	<u>\$20.30</u>

Assembly is straightforward. Begin with the boat first so that you will have someplace to go with your gear. Either follow the manufacturer's recommendations for color scheme or use your own judgement. We deliberately left off the aluminum paint on the hull since we felt that this might have an undesirable effect on the radio. With plastic there is absolutely no need for water proofing of any kind on the hull.

When the boat has been completed you can turn to the Mighty Midget actuator. Drill three holes in the large gear as shown in the drawing of the 7 to 1 gear with a 1/16" drill. Sweat solder in two small pieces of 1/16" wire at holes marked A to act as stop. The center hole at the top is used to work the push rod which in turn goes to the bell crank mounted on the rudder. A drawing of the bell crank is shown. It is not neces-

sary to use rubber band centering although this could be quite easily done on this particular installation by soldering a centering lever of 1/16" music wire on the back face of the pulley and running the rubber bands to the bottom of the boat. This would provide a strong enough self centering action. If your pulser has a tendency to drift slightly this might prove desirable.

Begin construction on the receiver and completely build it and check it out at this time. Begin installation in the Insta-Pak, installing one Acme #6A battery box and one Acme #14 battery box and receiver. Make the installation by drilling the required holes in the boat hull and the Insta-Pak plastic box. Mount by bolting through the boat hull, the plastic box, and the battery box using 4/40 x 3/4 inch bolts. Use washers and come up into the boat from the underneath side using nuts on the inside of the plastic box. Complete installation of R/C gear in this manner. Use contact cement to hold receiver.

Use a small piece of aluminum and a pin jack at the top front of the hull for antenna mount as shown in the photographs. Use 2/56 x 1/4 inch bolts to mount aluminum. Your antenna is one foot piece of .040 music wire, on one end solder a phone tip, on the other place a small plastic ball to prevent damage to eyes and clothing.

If desired a piece of styrofoam may be placed at the rear of the boat. Cut a size just to fit and slide in place. This will help make the boat unsinkable should disaster overtake you.

Install your meter jack and your switch on the top lid of the Insta-Pak and complete your wiring running wires out for your actuator batteries and Mighty Midget actuator and the antenna. Install the Mighty Midget in the rear center of the boat as shown in the photographs. Install the two #6 batteries on either side of the Mighty Midget again using 4/40 bolts with #4 washers on their heads.

Use a generous dab of cement on the head of each bolt you used in the construction to help waterproof. Care must be used during the life of the boat to make sure that these joints stay waterproof especially when the boat has had a rough landing and possibly skidded ashore.

The Mighty Midget Actuator hookup is shown in the drawings. Reasonable care following good construction practices will give you a trouble free unit for a long time.

Make a motor mount of aluminum somewhat longer than the present motor mount since the Cox Babees will need to be mounted somewhat higher than the mount provided (in order to swing the 6/4 prop). Mount this using washers to give you an approximate three degrees of right thrust to help offset torque.

Using 3/48 x 1/4 machine screws mount the motor to mount.

Make a connecting shaft to be used on the bell crank and the Mighty Midget motor. A small piece of retaining wire made of light wire may be used to put on the opposite side of the gear so that it will be held in place. A drawing of this is shown although individual applications will have to determine the length. This completes the installation and you are ready for fun with Fast I. Install A and B batteries and you make a distance check on the radio. Put boat in water to tune. This is particularly necessary with a hard tube circuit since water has a loading effect and there will be a change in the sensitivity setting. Tune the slug coil for the greatest drop in current. You are now ready to install your actuator batteries and check out your actuator with your pulser at your transmitter. In practice your pulser wires right across your present key. It is perfectly possible of course to work your thumb fast enough to keep a relatively straight line with a slow electric driven boat but we would not advise it for Fast I.

On your initial run, when you are sure that your radio gear is operating correctly, begin your motor and check for any vibration difficulties. It may be necessary to tighten the relay spring somewhat although we did not find it necessary on the original installation. Start motor and turn needle valve so it runs rich for the initial go around until you can become familiar with the boat. As you progress in piloting skill, you can rev the motor up till it fairly screams and watch Fast I really scoot along the water. Happy Landings!

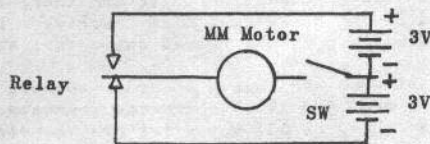
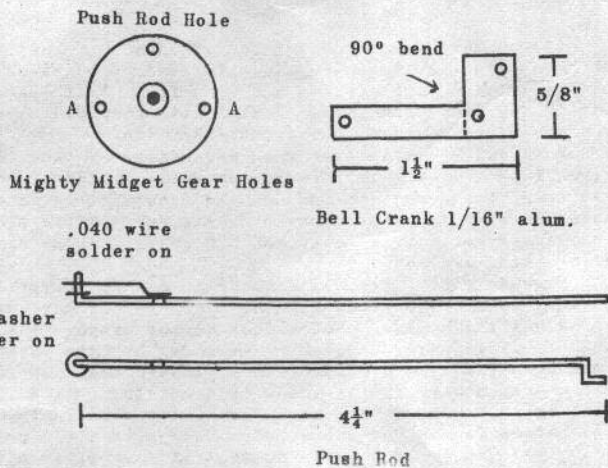
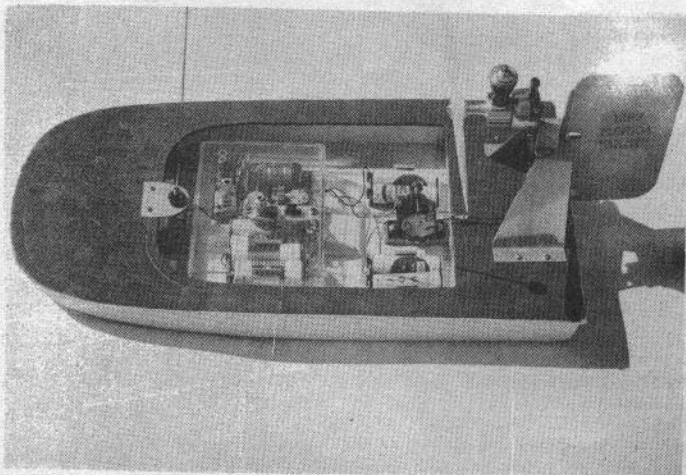

# TRANSISTORS CAN REPLACE RECEIVER RELAYS

SAY GOODBYE TO VIBRATION, ADJUSTMENT, CONTACT WORRIES

BY OSCAR L. SHULZ

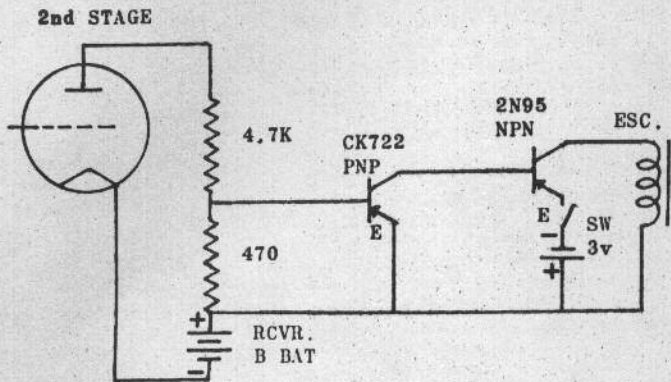

When we began experimenting with transistors to take the place of relays, a single transistor was of course the goal. But a few measurements on three different power transistors (2N95, 2N256, and 2N68) pointed out the need for a little more power than is normally available from a two stage North American or a single stage (RK61) receiver. The requirement between base and the emitter is in the order of 5 mils at .25 volts to give 250 to 300 milliamperes in the collector-emitter circuit using 3 volt batteries. Thus the circuits which have been developed are two transistor circuits.

The first circuit produced operated from the second stage of a North American receiver. It controlled the Bonner Compound Escapement with rising current pulling in at about 1.2 mils. As shown it uses a CK722 (PNP) driving a 2N95 (NPN).

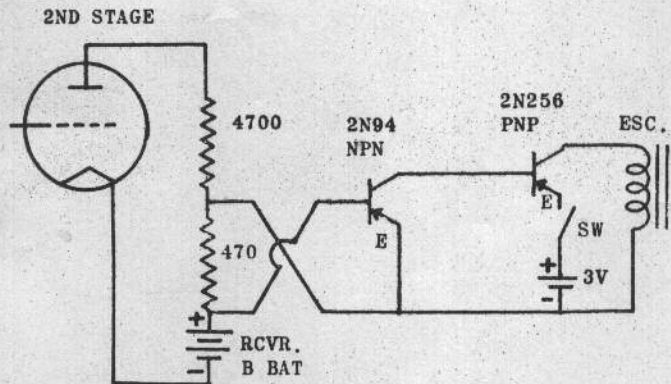

Since the 2N95 is a little bit on the expensive side at \$6.95 a second circuit has been tested and appears to perform equally well. It consists of a 2N94 driving a 2N256. The 2N94 is a Sylvania transistor selling for \$1.70 and the 2N256 is a CBS transistor costing \$1.50.

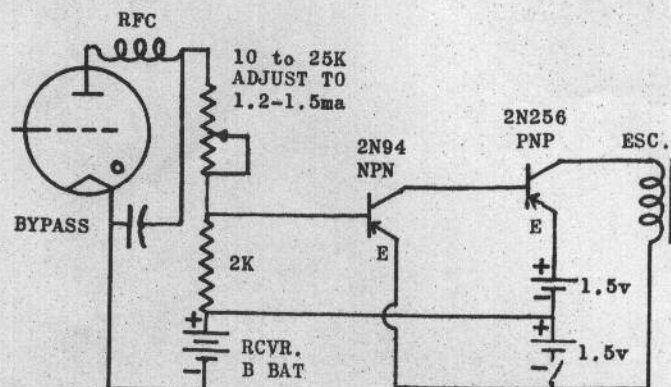

The third circuit using again the less expensive 2N256 permits the operation of the escapement on a falling current of an RK61. Reading the plate current of the RK61, the escapement pulls in at about .6 milliamps and drops out at about .9 milliamps.

This circuit could, of course, be used to follow a single hard tube as well as an RK61. It is expected, however, that adjustment of the resistor across the input to the 2N94 would be somewhat more critical in view of the fact that the hard tube provides a different type of current change than a gas tube and it is also subject to decreasing signal strength.

Pulse operation in experiment with the push pull circuit arrangement using transistors leads us to believe that it would probably be safer to use one of the above circuits with the pulse actuator being spring loaded.

# SOLDERING TAKES TECHNIQUE

BUT IT'S EASY TO LEARN



To the advanced R/Cer soldering presents no particular problem. For the beginner however, soldering is a mystery. Even with the purchase of completed R/C units the installation must still be made and there the soldering iron comes in.

The importance of making correctly soldered joints can not be overemphasized. R/C operators should look upon each joint as the most important one in the whole series of the ones that they will need to make in their model since failure of one joint can cause the model to careen.

As with many things, having the right tools for the job are important factors to its success. First of all let us consider the soldering iron. Most R/Cers possess a medium iron which they use for normal jobs such as landing gears, prop shafts, and so on. For actual receiver construction this type of iron is probably too large but it may be used for the wiring installation providing care is taken at the receiver joints. Obviously, if excessive heat is applied to the delicate components used in R/C harm can result. One of the main essentials on the other hand for a good solder is that the joint should be really hot; hot enough so that the solder will flow freely when applied. One of the better irons available for R/C work is the unger, which is available with a variety of tips. Most users seem to prefer the 37½ watt since this will provide them quite a good bit of heat and yet be small enough to prevent damage to the small R/C components used. It is available in a chisel point and a pyramid point. For R/C applications either will be found good.

The solder itself must again be of the right type for R/C use. Resin core type is ideal as it melts easily and can be gotten into awkward corners without difficulty. Furthermore, it saves a hand by containing its own flux. Never, on any account, should acid core solder be used or any flux containing acid when wiring in R/C installations. This will eventually corrode the wire and result in a break, probably in mid-air due to vibration. Ersin multi-core is an excellent solder.

Now that we have the correct type of iron and the right kind of solder, let us see how to obtain the right kind of joint. Cleanliness is absolutely essential. Otherwise the solder will not take to the metal surfaces we wish to unite. Scrape the terminals, lugs, and eyelets so that they will show a bright shining metal all over. With the stranded insulated wire we use, the actual wire beneath the insulation remains clean and free from tarnish provided it is stripped just prior to the time of soldering. Do not bare more wire than necessary since a greater amount of wire can lead you to trouble by shorting over onto other connections.

Your iron should be tinned. Allow time for iron to reach its operating heat and then clean the point with a small file or steel wool. Next apply the resin core solder which should run over the surface of the iron on its own accord leaving a bright surface of solder. The iron is now tinned and ready for use. Now tin the surfaces to be joined. Most of our solder connections will consist of a wire joined to a lug which will not take long to heat up. In fact with wire both iron and solder can be applied almost simultaneously. In the event of a lug apply the iron followed by the solder as second layer. The solder should run freely over the entire surface. If not, then either the surface is dirty or the iron is not hot enough. It is important to twist the bare wire tight before tinning it.

Now apply the iron and the solder and allow it to flow freely. It should not be necessary to apply the iron for more than just two or three seconds at the most.

Should it be necessary to solder very close to a small component, it is desirable to use a long nose pliers which is held between the solder joint and the component itself. This will absorb the heat away from the component into the pliers.

Never solder a joint with an iron that will barely run the solder. This, coupled with dirty connections will almost always result in a high resistance or resin joint. A high resistance or resin joint can cause no end of trouble through building up resistance at that point. Outwardly it looks good and will often stand up to a pull test but hardly it is no good and may cause you to have malfunction.

Clean up the excess of the resin which has flowed around the joint by using a razor blade or a knife.

Good common sense with the use of the right tools makes soldering easier. Practice will provide the necessary know how so that good soldering techniques will become operating procedures.

# R/C GLOSSARY

## FOR THE BEGINNER

One of the biggest stumbling blocks to the R/C beginner as he plans to branch out and start construction of his own equipment, is the matter of identification. Most of us can remember when we didn't know an antenna from a pole in the ground.

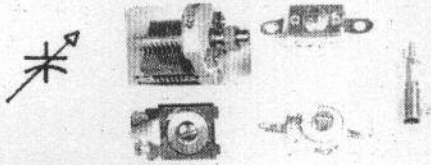

Variable capacitors or trimmers. Air, compression, ceramic and tubular types.

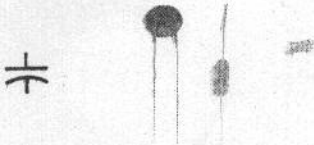

Fixed capacitors. Come in variety of sizes -- smallest physical size generally used in R/C.



Electrolytic capacitors. Used in advanced R/C circuits. Polarized and circuits + or - must be observed.



Diodes. Used to rectify alternating current into Direct Current. Also used as detectors.

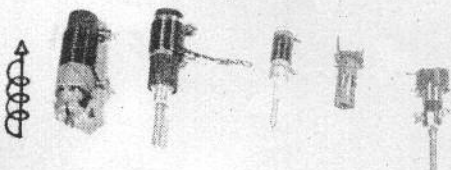

Dust core slug tuners come in variety of sizes. Use core specified by designer, and unless you have grid dipper stick to coil form specified.



Air Core Coil. Generally used in transmitter and referred to as L in schematic.

To help on this, Grid Leaks is preparing a series of articles which will not only help identify, but give some of the fundamental information needed on each of the items shown in the schematic diagram and photos below. Color coding will also be covered.



Quench coil or transformer. Used in hard tube circuits for sensitivity. When there are lines between coils indicates it has an iron core.



Radio Frequency Choke. Come with lateral single, double and triple pi windings. Substitutions are tricky. Stick to specified one.



Resistors used in RC are generally 1/4, 1/2, 1 watt sizes. Mostly composition construction although some wire wound sizes used.



Variable Resistor or Potentiometer. Used in circuit where variable resistance is required.

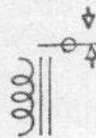

Relay. Changes small electrical impulse into a large one to operate actuators which require more current.



Switch--Push type used for transmitter keys. Slide type generally used in installation in plane. On slide look for knife action.

# WAG Dual Servo Design Considerations

LT. COL. H. M. BOURGEOIS

The WAG Dual Proportional System requires a servo to operate the control surface and is pulsed proportionally in either direction from the neutral center. In order for the control surface movement to be truly proportional the servo must have a center neutral position to which it can be returned each time the control stick at the transmitter is returned to neutral or the fail safe button is pressed. In the present form of the system this means a mechanically neutralized servo by some type of device. This device must physically move the servo to the center neutral position when the pulsing is removed (Fail Safe). The mechanical neutralizing system actually opposes the pulse directing the servo to move away from the neutral center, therefore, absorbing some of the power normally applied to the control surface.

Most of the modelers flying the WAG D/P system use the double geared Mighty Midget electric motor, with a rubber band attached to the motor armature shaft. This shaft winds the rubber band when the servo moves off center, and the rubber band unwinding returns the servo to neutral when the Fail Safe is applied. Its main disadvantage is that the neutralizing rubber band absorbs more and more of the servo power as the control surface is moved to its full control position (Figure 1). The effective control surface is reduced by this action at high speeds, as the slipstream tends to blow back the control surface and the servo has insufficient power to hold the control surface at full travel (Figure 2).

The type of curve illustrated in Figure 1 gives smooth, easily controlled flights for normal flying, but reduces the control effect and limits aerobatics. The controls effects desired for aerobatics can be increased by putting a loose rubber band on the motor shaft to change the torque curve (Figure 1), however, this makes the model difficult to fly smoothly and it is easily over-controlled. A loose rubber band is not considered satisfactory for normal flying.

The ideal torque curve for a neutralizing device is the curve of Figure 3. This curve can be approached by adding two hooks on the first large gear of the motor (Figure 4) and using two rubber bands. This gives the neutralizing curve of Figure 5, which is good around the neutral position out to 1/4 movement. Then the two rubber bands wind up on themselves and there is practically no neutralization. A completely unsatisfactory situation as the fail safe is of no use.

By placing a loose rubber band on the motor shaft, and two rubber bands on the spaced hooks on the first large gear, as illustrated in Figure 4, a combination of the loose rubber band curve (Figure 1) and the double rubber band curve (Figure 5) is produced and the result is the neutralizing curve of Figure 6.

By experimenting with the size and length of the three rubber bands it is possible to match the neutralizing effect to the requirements of each individual model. This system has proven simple to install and set up and is very satisfactory in the field. By changing the rubber band on the main shaft it is possible to reduce the control effect and smooth out the control movement for the beginner, or to test a new model. Yet the model is still easily set up for contest flying.

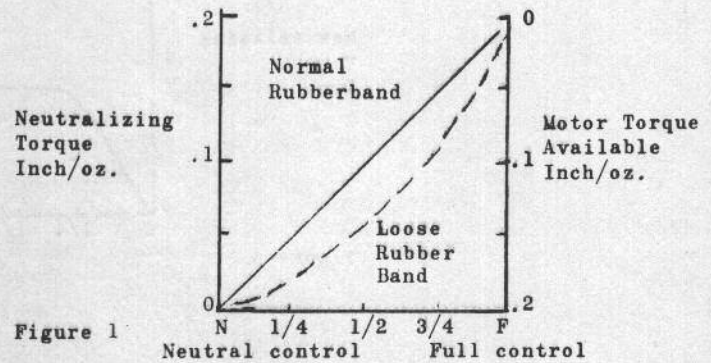

Figure 1

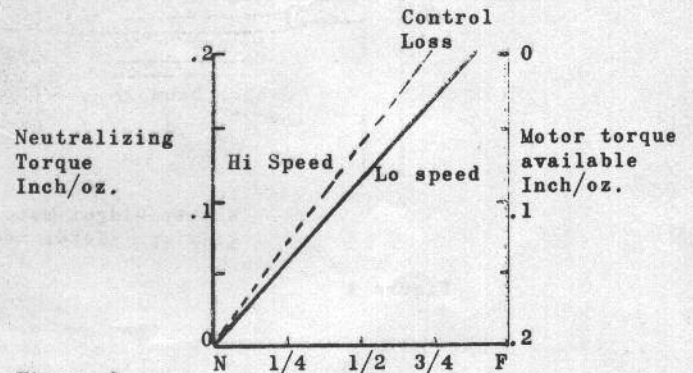

Figure 2

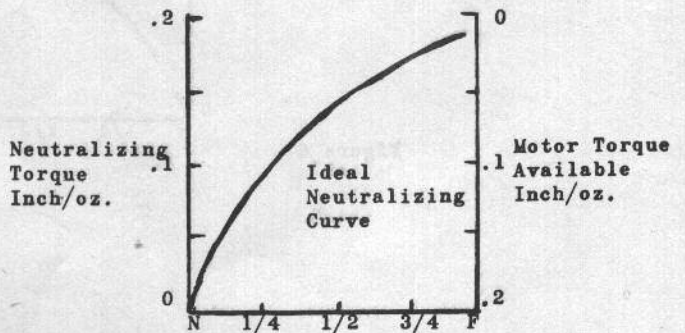

Figure 3



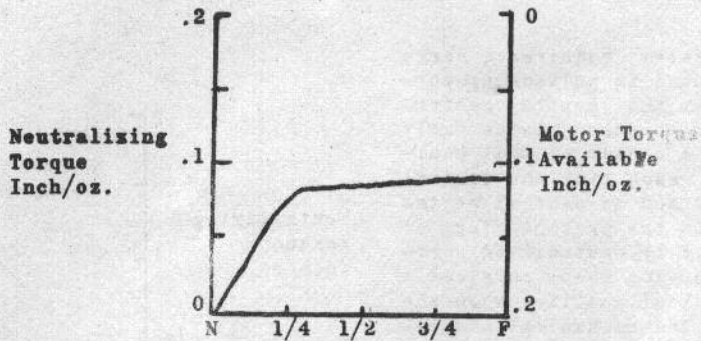
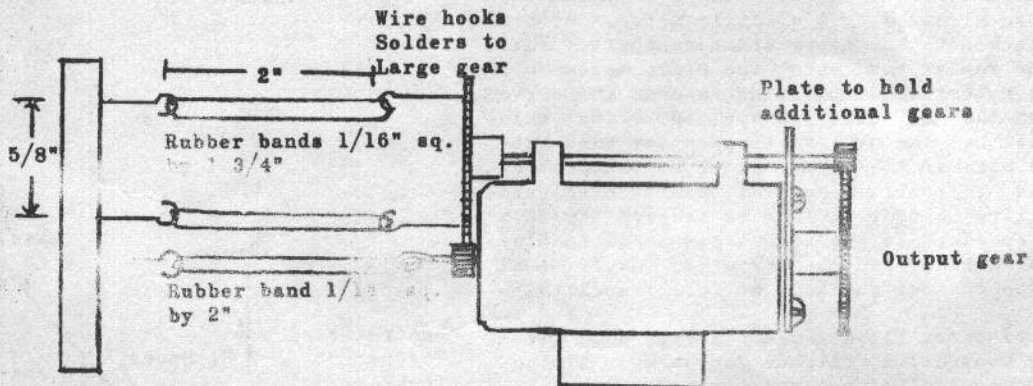

Figure 4



Mighty Midget Motor with double reduction gearing. Total Reduction 49:1

Figure 4

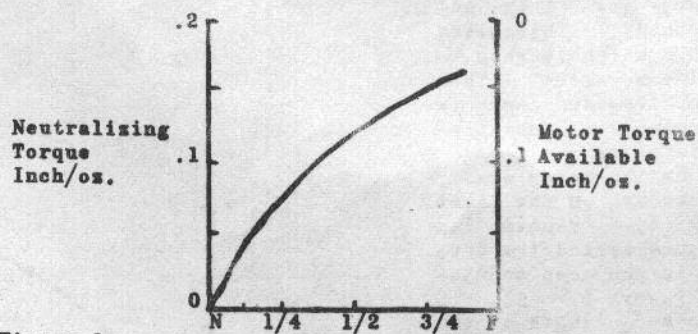

Figure 6

# Proportional Motor Control for the WAG Dual TTPW System

A GRID LEAKS EXPERIMENTERS CIRCUIT

BY GENE BRITZIUS & RUSS TOBEY

1-1-7

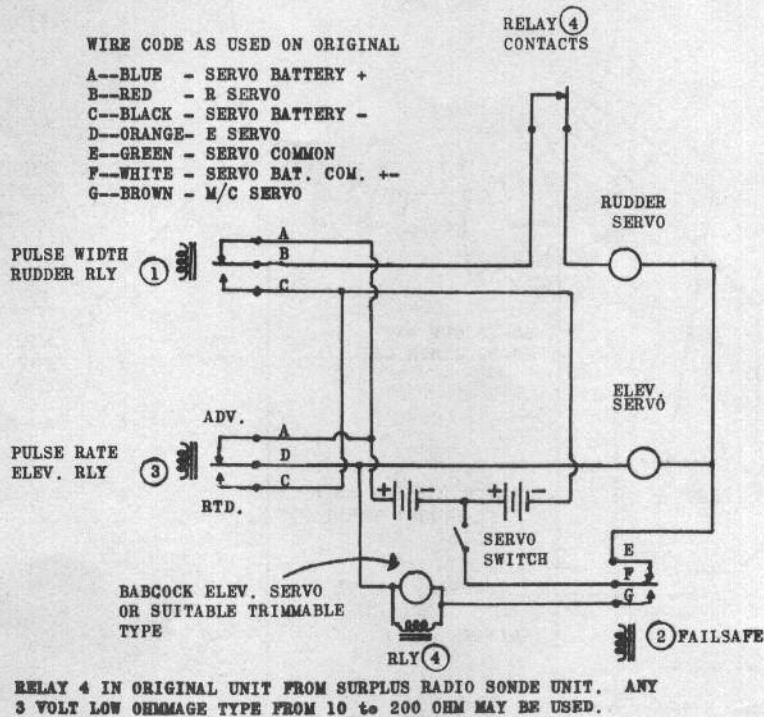

FIGURE 2--SERVO HOOKUP. NOTE THAT WIDTH IS USED FOR RUDDER WHILE RATE IS USED FOR ELEVATOR. THIS IS OPPOSITE THE ORIGINAL

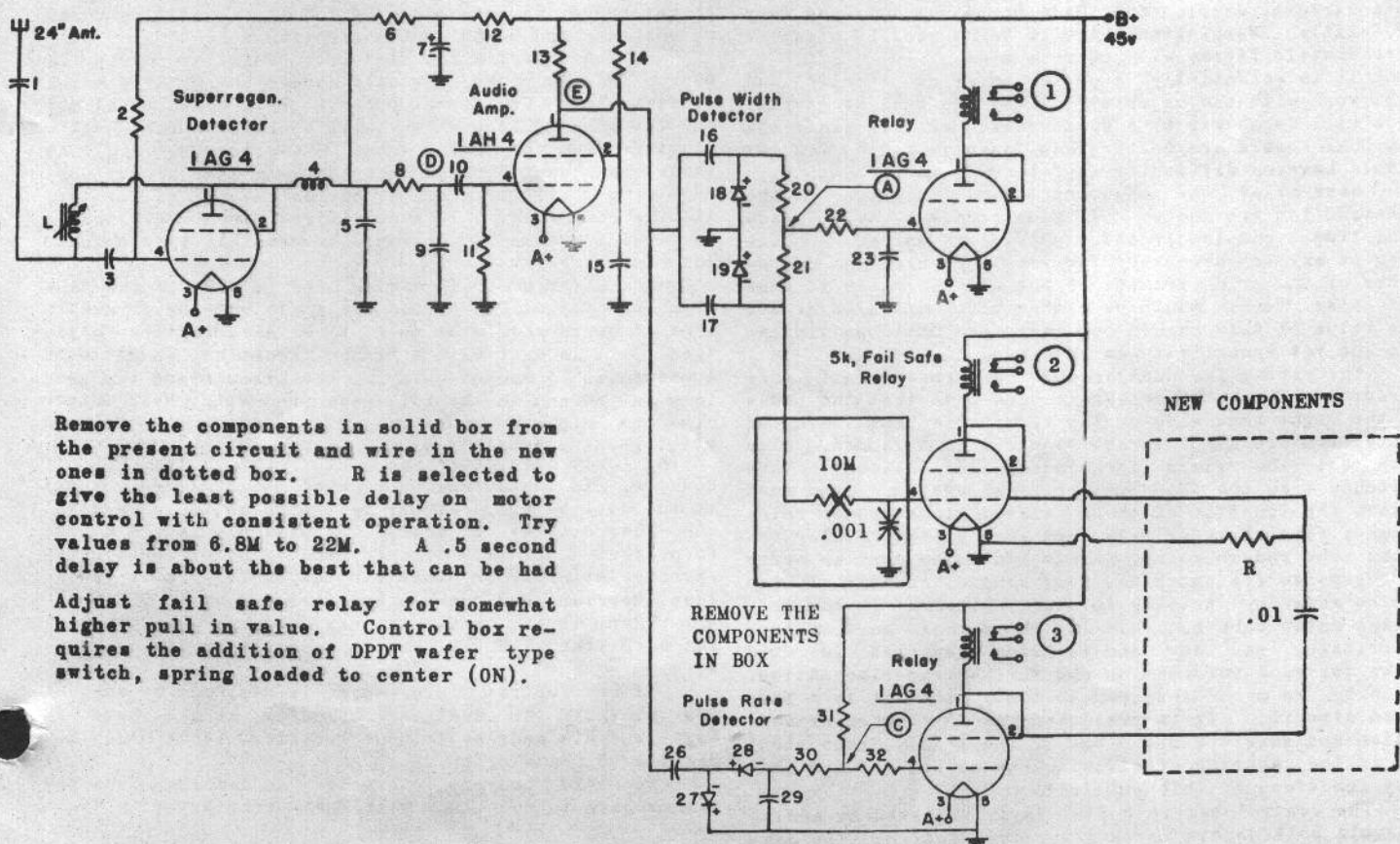

FIGURE 1--ONLY MINOR CHANGES ARE REQUIRED

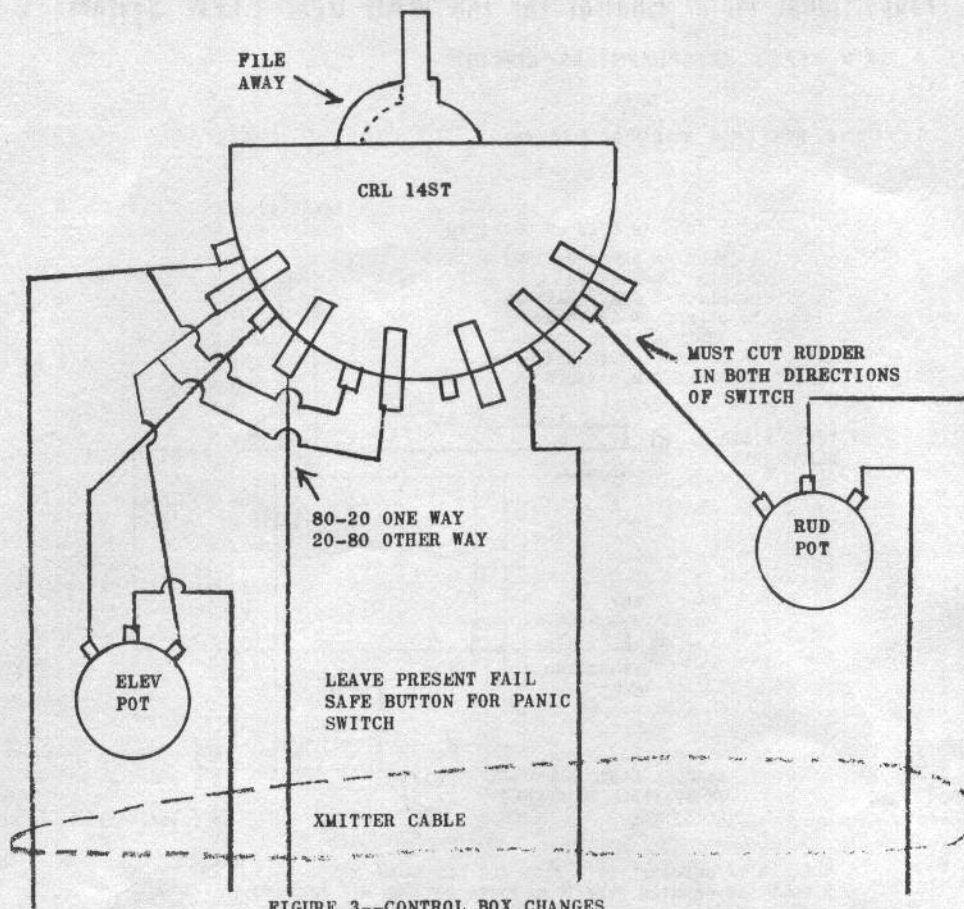

FIGURE 3--CONTROL BOX CHANGES

Have you been wanting to add proportional motor control to your WAG Dual so that by a flip of the switch you could get exactly the revs you want? Here is a circuit developed by Gene Britzius and Russ Toby of Seattle, Washington which is being used by eight or more Seattle flyers with never a miss.

It is essentially a pulse omission detector and will work with the majority of the WAG Dual Receivers. This will in no way be a construction article since the WAG Dual users are better than average radio men and should have no difficulty in following the schematic.

Several of the important points to watch in the construction are these: If your receiver, at the present time, completely stops pulsing in any stop position it may be necessary for you to change the components of the grid circuits of the side in which it does not pulse. This would be either part number 22 or 30. The value of this should be increased until pulsing is had and yet sensitivity is retained.

The wiring is done around the present fail safe circuit. Check the schematic and note that the parts on the right hand side of the receiver schematic in the dotted box are all that are required to be added. Also note that the relays for rudder and elevator are switched from the WAG Dual original system. You must switch the function of these relays. Your rudder relay becomes your elevator relay and your elevator relay becomes your rudder relay. This had to be done in order to secure sufficient bias. Of course, additional bias can be added by putting in diode networks in the grid of the motor tube but this is the circuit as developed by Britzius and Toby and is being presented in Grid Leaks for your information and further experimentation. It is by no means intended to imply that it is a finished circuit. It is presented for further experimentation and development. One of the great things about R/C is the sharing of circuits and is one of the primary functions of this publication.

The control box is quite simply altered by adding a double pole double throw lever type switch. The dia-

gram shows a single pole which was altered to make it into a double throw. Actually any two pole three position switch of any make will do. Its function must be to cut rudder on both sides of the throw and give 20/80 on one side and 80/20 on the opposite side.

In the installation itself an auxiliary relay is used. This is hooked directly across the motor control to secure the additional pulse. This could be almost any low ohmmage type which will operate on three volts ranging from 10 to 200 ohms. Needless to say that those which can be made to operate in the higher ohmmage range will be more economical as far as battery life is concerned. If a sensitive DPDT relay could be found for relay 2, it would be possible to eliminate low ohmmage relay 4.

The motor control device used is one of the Babcock elevator servos of the old style but any trimmable type of servo should be able to be used in this position. It is used with a Bramco throttle. There is an approximate .5 second delay in the circuit and the grid leak as chosen on the fail safe tube will help determine the minimum amount of delay that can be had and still retain sensitivity for the particular circuit. .5 lag isn't much after you become used to it. Cut off however, is instantaneous so that motor may be cut off at the desired speed simply returning switch to neutral.

Theoretically it should be possible to add a tube in present fail safe circuit and by using DPDT relay operate ailerons or other control. This is speculation, however, and has not been tried.

There it is, a circuit designed to give you more fun with your WAG Dual and increase your flying pleasure.

If any further information is desired we suggest you contact the designer directly at his home in Seattle. His address is Gene Britzius, 14807 8th N.E., Seattle 55, Washington.

We would be very interested in hearing from you with regard to your luck with this circuit.

# We Try the Aeromodeller Transistor Receiver Circuit

## A GRID LEAKS EXPERIMENTERS CIRCUIT

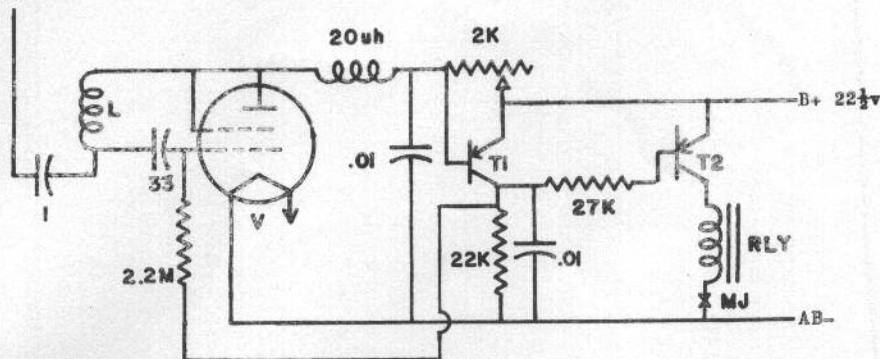

L 32 turns #32 on 1/4" CTC Red Dot  
 V 3V4, 6007, 1AG4

In the May, 1957 issue of the Aero Modeller magazine, the British publication, there appeared the circuit and construction article for the Aeromodeller Transistor Receiver designed by Tommy Ives. A glance at the circuitry and the reading of the article convinced us of the desirability of conducting experiments with this circuit using American components to see if here might not be one of the answers that we have been looking for in using transistors on 27 1/2 spot.

Claims for this receiver were current rise from approximately .3 of a mil to 4 plus on only 22 1/2 volts of B through a 5K relay. The original circuit called for a 3V4 tube in which both sides of the filament were used and in order to test this out the circuit was built up as per plans. This was during the summer months when warm weather was upon us and ground checks, plane checks, and other checks revealed that this circuit did as promised. So we were quite enthused. Plans went underway to build a submini version using the new Amperex 6007 or the 1AG4 in the detector in an attempt to lighten weight, cut down on size and lower filament drain. This test model is shown in the picture. It, too, performed beautifully as promised and we thought we were on the track of something pretty hot.

The potentiometer acted as somewhat of a sensitivity control but it didn't seem critical. Then there came a sudden cold snap and the receiver started acting up. A quick check showed that it was extremely temperature conscious, a fact which has been admitted in the October issue of American Modeler and we feel the circuit, though basically excellent, needs considerable improvement.

It is presented in these columns for the serious experimenter who is looking for the features of this type of receiver to see if the temperature stabilization may be had. In our test models we used the CK722 and it is entirely possible that a lot of the temperature problems can be cured by using a better and a higher grade transistor. Certainly temperature stabilization may be built in without too much trouble although there will be a little more complex circuitry.

Essentially the Aeromodeller Transistor Receiver, we feel, is basically a good design and if it is built with the shortcomings in mind it will be an excellent performer. It is extremely temperature conscious, however, and if there are any temperature changes over the initial tune up an additional tune up will be required or else a fly away will be had. In as much as temperature changes are not likely to occur during a flight this, we feel, does not present too much of a problem.

So if you are looking for a receiver which utilizes only a single low drain vacuum tube, features a high relay current change through the transistors and has a relatively unfussy sensitivity adjustment, the receiver as is may be for you.

It is with that in mind that the circuit is presented in these columns.

No detailed wiring instructions will be given since we do not feel that this is a receiver to be tackled by the beginner. The tuning instructions as presented are extremely important in view of the fact that it involves a slightly different technique than almost any other receiver that we have encountered.

Certainly if you have been used to gas tubers the technique is a lot different. Also the technique is considerably different over the conventional hard tubers. Insert the tube only, not the transistors, and connect the batteries--A battery 1 1/2 volts, B battery 22 1/2 volts--placing a switch in both the B plus and the common negative. A double pole single throw will do. Insert meter between B plus lead and the B plus battery (a 0-5 ma will do O.K. here). Switch on, meter should read approximately .2 mil. Squeeze the RF choke with your fingers and current should rise to about .5 mil indicating the receiver was super-regenerating and has been knocked out of oscillation by the touch of your fingers.

Switch off, insert T1 in the flea clips making sure the red spot is in correct position. Then switch on. Adjust the variable resistor until meter shows a reading of approximately 1 mil. The adjustment here is critical and should be made to the point of which the current is just about to drop. Switch on the transmitter and adjust tuning coil slug until meter shows a drop of .4 mils or more. Switch off and connect T2 in place, again making sure it is inserted correctly. Move the meter to a position between the relay and common negative as shown on the schematic. Switch on and adjust pot until reading is at approximately .2 of a mil and is just about to rise. Tune slug until maximum rise is obtained, completing final tuning at a range of three hundred feet or more. Should the idling current be above .2 of a mil but the set working O.K. then it would be best to insert a 10K resistor between the base of T2 and B plus.

We present the circuit for your study and evaluation. We would appreciate being advised of any results that you have on the circuit. Any circuit changes that you develop please share with our other readers.