

SPECIFICATION AND INSTRUCTION SHEET
FOR THE HERCULES EIGHT CHANNEL SIMULTANEOUS TRANSMITTER

INTRODUCTION:

The Hercules is a high quality, efficient and reliable eight channel simultaneous tone transmitter. It is a precision instrument, fully production engineered and thoroughly tested. Much more powerful than the now superseded T-8, the Hercules is backed by many years experience accumulated in manufacturing the T-8.

GENERAL REMARKS:

Federal Communications Commission Regulations (Part 19, Citizens' Radio Band, Revised 9/23/58) require that the frequency of the radio energy radiated be within 0.01% of the specified operating frequency for transmitters with less than 3 watts input. The Hercules contains a crystal controlled fundamental Pierce oscillator operating at 1/3 the radiated frequency (9.085 mc for 27.255 mc output). The crystal is a fundamental type cut to 0.005% tolerance and meets military specifications. In addition, each crystal is checked in the Hercules circuit to insure output specification compliance. The crystal is stamped with the oscillator's fundamental frequency. The transmitter's fundamental oscillator frequency is tripled then amplified by a separate tube. Thus, the Hercules is a MOPA type of transmitter, fully meeting all FCC stability and frequency requirements. It must be pointed out that this is true ONLY when operated with CG crystals. Standard .005% crystals obtainable on the market are overtone types and will not be "on frequency" when used in this fundamental circuit. In addition, the CG crystal, a more rugged type, is made to withstand the "hi-drive" conditions encountered in the Hercules.

LICENSE REQUIREMENTS:

In order to lawfully operate the Hercules, like all Citizens' Radio Band transmitters, the user must obtain an examination-free permit from the Secretary, FCC, Washington 25, D. C. The permit, Form #505, is a simple questionnaire requiring no radio technical knowledge.

ASSEMBLY:

Remove the back of the transmitter and unpack the tubes and the crystal. Insert these items in their proper sockets (see diagram). Two of the 1L4 tubes are color coded, and although the transmitter will operate with them in any of the three sockets, the audio tones will require the least adjustment when the color code is adhered to. Do not install the antenna (packaged and mailed separately) until tuning is completed. Install one lantern size 1½ volt filament battery (Burgess 4FH) and two 67½ volt batteries (Burgess XX45 or equivalent) as shown in diagram using jumper supplied to connect the 67½ volt batteries in series.

OPERATION:

Position the on-off switch to the ON position. The neon indicator on the front panel should light up. If the lamp does not light, check the 67½ volt batteries and their connections. The batteries should be periodically checked. Replace the "A" battery when the voltage drops under 1.2 volts with the switch on. The "B" batteries should be replaced when the voltage drops under 110 volts with the switch on.

TUNING:

The Hercules is pretuned at the factory and comes ready for operation with possibly only slight tone adjustments necessary. The RF oscillator adjustments are sealed

SPECIFICATION AND INSTRUCTION SHEET FOR THE HERCULES EIGHT CHANNEL SIMULTANEOUS TRANSMITTER -- Page 2

with colored lacquer and FCC Regulations Part 19 amended should be read before tampering with these adjustments. The RF Amplifier (see diagram) can be tuned using a field strength meter. Simply adjust this capacitor for maximum field strength with the antenna fully extended. Keep one hand on the transmitter case and use a plastic screw driver to make this adjustment. The RF amplifier is tuned at the factory and if the transmitter should fail this adjustment will not be at fault. The back cover will have no effect on the tuning; therefore, a tuning hole is unnecessary.

The eight tones are variable over a limited range and these adjustments are located on both sides of the transmitter. They are marked to match the stick positions on the front panel. The two sticks on the left side will work simultaneously with the two sticks on the right. Controls other than those marked on the panel can be used by connecting to the matching relays. DO NOT TRY TO TUNE A STICK POSITION TO A RELAY NOT INTENDED FOR THIS POSITION.

To tune the channels have the receiver wired to its batteries and energized. Operate the transmitter with no antenna and the back removed. Turn the transmitter on and key any one channel. While holding this channel on, move the transmitter away from the receiver approximately 3 feet. (This will vary and if you have the transmitter too close it may block the receiver such that it will fail to function. This is caused by oscillator radiation that is not modulated.) Check all eight channels for single operation and make adjustments if necessary. After all channels operate with the correct key position tune for simultaneous operation. To do this hold any one channel on the left side (looking at the front of the transmitter) and key the right channels one at a time adjusting them as you progress. Repeat the procedure holding any one of the right channels, keying and tuning the left channels one at a time. Check all channels for simultaneous operation and refine adjustments if necessary. The two adjacent reeds on the receiver (L. RUD and ADV. ENG) may beat at a low frequency when keyed together. This is normal and these two channels should be avoided for simultaneous operation. After the channel tuning, replace the back cover holding it in place with the six metal screws provided. A final check can be made with the antenna removed and the back cover in place. Using the Atlas receiver, operation should be possible at a distance of three feet with the top of the transmitter pointed at the receiver antenna.

Install the antenna and screw only hand tight onto the stud provided in the transmitter.

The transmitter is now ready to use and will operate all tone receivers manufactured by F & M Electronics. No commitment is made regarding operation with receivers of other manufacturers.

Specifications:

<u>Type:</u>	Hand-held; easily carried and transported.	
<u>Case:</u>	<u>Dimensions:</u>	<u>Material:</u>
	Width - 7"	.040" aluminum, blue anodize
	Depth - 3-1/2"	<u>Weight:</u>
	Height - 9-1/2"	4 lbs., including batteries

Antenna: Telescoping, 58 inch chrome, removable. Antenna is fixed tuned for maximum efficiency.

External Adjustments: None

Circuit Components: Precision engineered printed circuitry - even to tank coil.

SPECIFICATION AND INSTRUCTION SHEET FOR THE HERCULES EIGHT CHANNEL SIMULTANEOUS TRANSMITTER -- Page 3

Operation Type: The Hercules is an amplitude modulated, crystal controlled, Class "C" station with an input power of approximately 2.7 watts.

Power Requirements:

"B" Supply - two 67-1/2 volt batteries, series-connected to provide 135 volts.
"B" current 20 ma.

"A" Supply - one Filament battery to provide 1-1/2 volts. "A" current 550 ma.

Stability: Better than FCC requirements under all conditions of temperature, battery voltage, and antenna loading.

Frequency: The Hercules is designed for operation on any of the following Citizens' Radio Band frequencies allocated by the FCC: 26.995 mc, 27.045 mc, 27.095 mc, 27.145 mc, 27.195 mc, and 27.255 mc. Unless a different frequency is specified with order, the standard frequency of 27.255 mc will be supplied. Operating frequencies may be changed simply by changing crystals. No retuning is required. Extra crystals are available on any of the above frequencies at \$4.95.

Modulation: The Hercules is amplitude modulated approximately 95%.

Audio Frequency: Channel frequencies are tuned to match the frequency of the reeds used in the receiver. All tones are variable over a range of 25 CPS to compensate for Reed Relay differences. Audio channels are stable to within one cycle per second over useful range of battery voltages and temperature.

Warranty and Repair Service:

Our standard written 30-day warranty card is enclosed with each unit. F & M Electronics maintains a fully trained staff of specialists for the prompt repair of CG equipment. All repair charges are itemized and nominally priced.

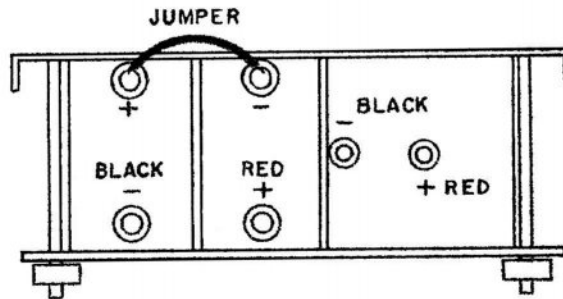
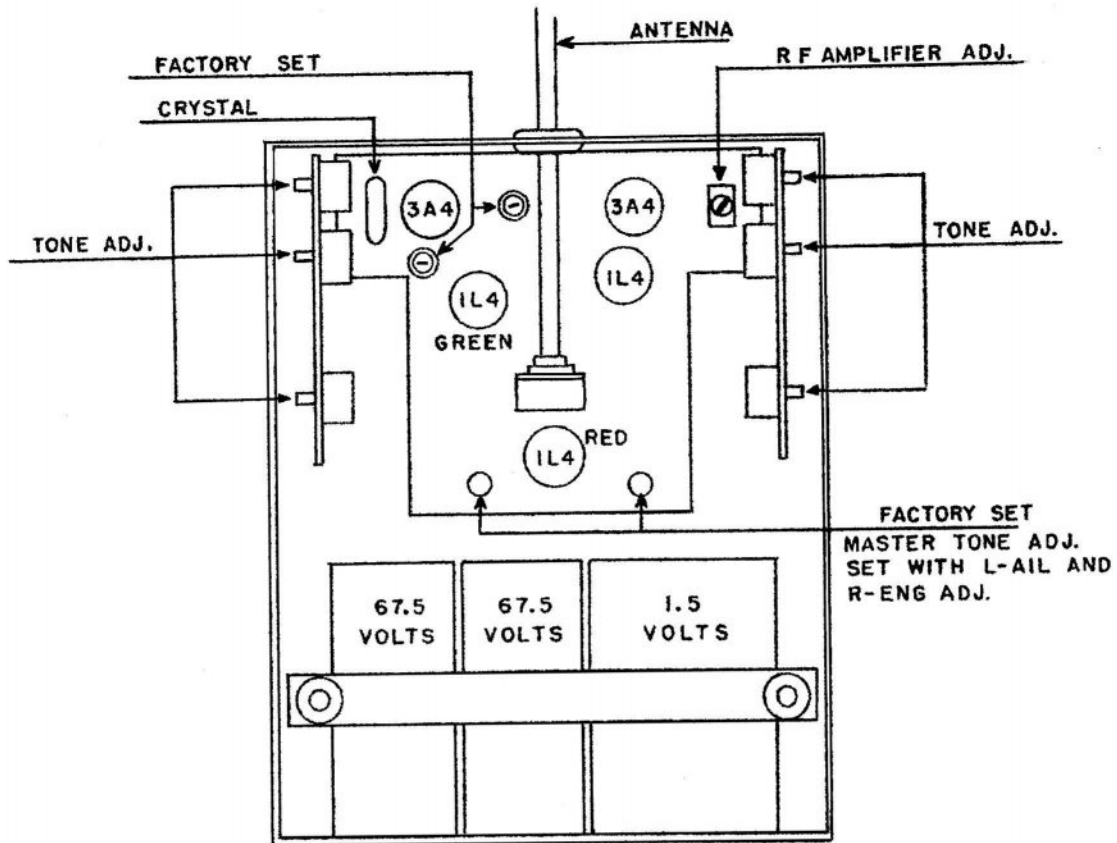

"HERCULES"

F-M MULTI-CHANNEL TRANSMITTER

12-9-59

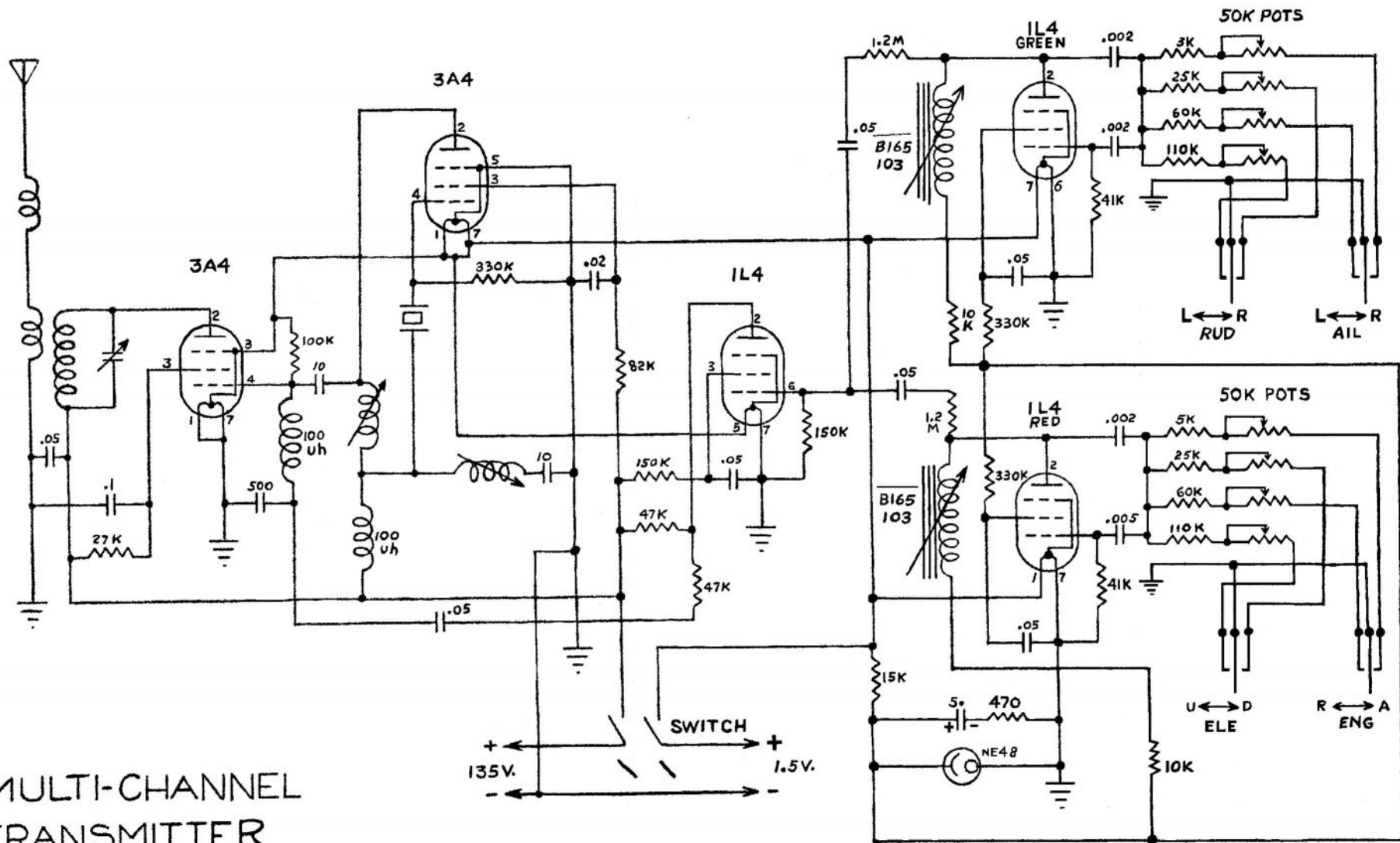

F & M ELECTRONICS, INC.
153 VERMONT, NE
ALBUQUERQUE, N. M.

HERCULES