

ACE R/C, Inc.

DIGIPACE I

ASSEMBLY INSTRUCTIONS

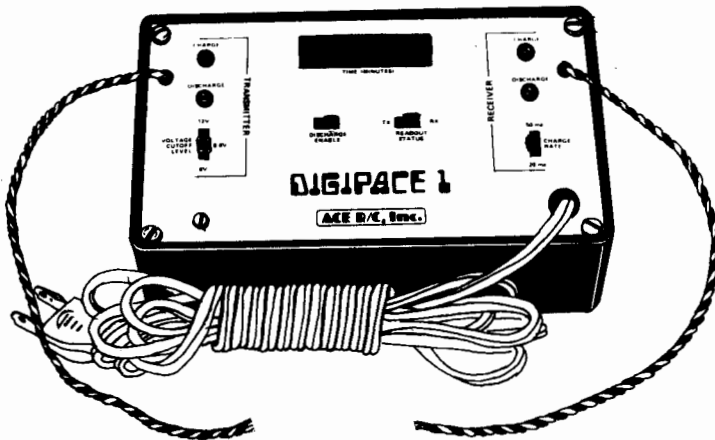

I. INTRODUCTION

You have ahead of you an enjoyable experience... building one of the most sophisticated pieces of lab equipment available to the R/C hobbyist. No compromises have been made in the quality of the components, design, engineering, and performance of this unit as we are sure you will find while you progress through the assembly.

We at Ace R/C are certainly proud of this design and know that you will be too, when you have completed it. Take your time, do a neat job, and then show it off to your envious friends; they will be impressed!

Begin by reading two of the enclosed pieces of literature--the "Kit Builder's Hints" to show how to properly solder and identify parts, and the "Operation Manual" to learn what this unit will do when you are done. Then read through the remainder of this instruction manual to familiarize yourself with the Digipace assembly procedure. Obtain the proper tools, clear a spot on the workbench, set aside some quiet time, and begin--take your time and enjoy!

II. CIRCUIT DESCRIPTION

By: Leonard W. Barker, Designer
Mid-Continent Communications Co.
Independence, Mo.

The design of the Digipace I uses basic analog and digital technique's, with the timing system being the only difficult to understand area. The Charge/Discharge portions of the Digipace are basically the same in both Transmit (TX) and Receive (RX) sections and will be discussed first. The only real difference being the charge method and switch positions used. These differences will be brought out in the following text.

TX:

In the Charge Mode, the charge is provided via CR1, Q1 and R7. When the Q output of IC U4B is at Vcc (5 volts), Q3 is

saturated and supplies a ground for R15. With R15 grounded, approximately 8 MA flows through zener diode VR1 and thereby causes the voltage across the Q1 (Base-Emitter)-R7 combination to be about 3.3 volts. Since the base-emitter voltage of the transistor is generally 0.7 volts, the 3.3 - 0.7 volts equals 2.6 volts across R7 or roughly 51 (2.6V/51 ohm) MA. It can be seen that Q1 will attempt to maintain the Charge current constant, regardless of the TX battery voltage (6 through 12 volts) since the voltage across R7 is fixed by the zener diode. Actually R7 is in parallel with the R5-DS1 charge indicator and the values have been chosen such that the total current through the two paths equal 50 MA typical. When the Discharge Enable switch is pressed, a reset pulse is applied to the flip-flop IC U4B. This causes the Q output to go to zero volts and Q to go to Vcc. Q3 now is turned off and the Charge cycle ends. With Q at Vcc, the TX discharge control R26 has about 0.765 volts across it. With zero volts across R16 - R17, the op amp U2C has a higher voltage on the non-inverting input and therefore the op amp output goes positive. As the op amp output goes above 0.7 volts, Q4 begins drawing current from the TX battery through R16 - R17. This current continues to increase until the two inputs to the op amp are equal or 0.765 volts. Since this means there is 0.765 volts across R16-R17, then the discharge current must be 0.765/2.55 ohms or 300MA. This discharge current will continue until the battery reaches the preset Cut-off-Voltage level, the unit then switches back to the charge mode. This is accomplished by the op amp comparator U2B. The TX battery voltage is sensed through R1 - R2 and is applied to the comparator at a reduced level on the inverting input. A Cutoff Reference voltage is also fed into the comparator, but the reference is applied to the non-inverting input. This voltage can be varied by slide switch S1 for either 6, 9, or 12 volt batteries. As the battery discharges and its voltage drops, the voltage on the inverting input eventually drops below that on the non-inverting input and the output of U2B goes positive. This causes the output of OR gate U3A to apply a positive voltage to the SET input of U4B, and the flip-flop changes state such that Q is again at Vcc and Q is again zero. This of course is the original Charge Mode. The discharge mode is indicated by DS3 which is driven by Q7. Q7 is turned on when Q output of U4B is low, therefore DS3 lights during the discharge mode. The preceding discussion shows how the Charge - Discharge cycle is controlled, and indicates that the Q-Q outputs of the flip-flop U4B may be used to control the discharge cycle Timing Circuitry which will be covered later.

RX:

With a few exceptions, the RX section operates the same as the TX section. The only major difference being the cutoff voltage is fixed by voltage divider R10-R11, and that the charge circuitry has two charge rates. During Charge Mode, Q output of U4A is at Vcc and transistor Q5 is saturated. With R18 grounded by Q5, current flows through the base of Q2 and causes Q2 to saturate also. This applies 20 volts to charge resistors R13 and R14 via diode CR2. The charge switch S2 selects either 20 or 50 MA charge rates for the various sized RX batteries. R13 and R14 values are selected such that they, in conjunction with charge indicator DS2-R1, will provide the two desired charge currents. When the Discharge Enable switch is pressed, Q of U4A goes to zero and Q goes to Vcc. This sets the discharge current at 300MA as before, and with Q at zero the transistor Q5 is off and therefore the charge circuit is disabled. The remainder of the cycle is the same as in the TX section.

TIMING CIRCUITRY:

The Digipace timing circuitry allows independent timing of both TX and RX discharges with an accuracy equal to the 60HZ AC line. The basic timing reference is generated by IC's U7 and U8. U7 is a dual 4-input AND gate and U8 is a 12

stage ripple (cascaded flip-flops) counter. A sample of the AC line is taken via R37 and is conditioned into a square-wave by U7A, this is then used to clock ripple counter U8. The output of specific ripple stages (numbers 4, 6, 7, 9) are fed into U7B, such that when 360 square-wave cycles are counted by the ripple counter, the four outputs will all be at Vcc. This causes the output of U7B to go to Vcc also and thereby causes U8 to be reset to zero. With all counter outputs at zero, the AND gate output returns to zero and the counting cycle repeats.

Since a pulse is generated at the output of U7B every 360 counts, it may seem that with a 60 HZ output the pulses will occur once every six (60 per second/360) seconds or every tenth of a minute. These pulses are used to clock the display counter U9. U9 is a very unique IC in that it contains four 0-9 decade counters, storage latches for each counter, and multiplexing/driver circuitry for driving the four digit display. An important feature is that the IC allows either the contents of the counters or the latches to be displayed simply by setting the DS (display select) input to either ground (latches) or Vcc (counters). By using this feature, it is possible to independently time the TX and RX discharge cycles.

As mentioned earlier, the outputs of flip-flops U4A and U4B are $Q = V_{cc}$ ($\bar{Q} = \text{zero}$) on charge and zero ($\bar{Q} = V_{cc}$) on discharge. As can be seen, the time base output from U7B is fed to the clock input of U9 via R32. When the cathode of CR3 is at Vcc, the time base pulses can pass through R32 and cause U9 to count up at the rate of one digit each six seconds. When the cathode of CR3 is taken low (zero), the pulse voltage is dropped across R32 and U9's display counters remain unchanged. Since CR3 is connected to OR gate U5C, either input must be at Vcc in order for U9 to accumulate a count. The gate inputs are the \bar{Q} outputs of U4A-B and therefore the gate output will be high whenever the \bar{Q} outputs are high or in other words when in the discharge mode. Therefore when the Discharge Enable switch is pressed and both Q outputs (U4A-B) go to zero (\bar{Q} to Vcc), the output of U5D will be zero and U5C will be Vcc. Also a reset pulse is generated via U5C which sets U6A-B, and U9 to zero (outputs equal zero). Under these conditions the counters of U9 begin accumulating time and, with Q of U6A at Vcc, this count is also read into the latches of U9. When either TX or RX switches back to charge mode, one Q input to U5D will be at Vcc and this will cause U5D's output to go to Vcc also. After passing through time delay R31-C2, the Vcc level signal sets U6A to $\bar{Q} = \text{zero}$ and clocks U6B. With the \bar{Q} output of U6A fed into the latch control of U9, the zero input causes the U9 latches to store the present count now displayed. Since only one input to U5C is zero, the output of U5C remains at Vcc and U9's counters continue to accumulate time for the remaining discharge section. The time for the first section to switch back to charge is unaffected, since it is stored in the latches. When the remaining section switches to charge mode, the output of U5C goes to zero and U9's counters stop accumulating time. . . We now have TX and TX discharge times stored, but we don't know which is in the storage latches and which is in the counters. This is the purpose of U6B. As mentioned earlier, when either TX or RX switches to charge mode, it's Q output goes to Vcc and thereby causes U5D and then U5A to go to Vcc. This Vcc level not only sets U6A, it also clocks flip-flop U6B. This flip-flop is a D-Type which when clocked, causes its Q output to go to whatever level is present at the D input at moment of clocking. The U6B D input is connected to the RX Q output of U4A. If the TX section switches first, the Q output of RX will be zero since it is still in discharge mode, and therefore U6B will have a zero output clocked into its Q output which we label TX. Since U9 displays the latch contents when DS (display select) is zero, the above condition would cause the latch to be displayed when the Readout Status switch S4 is in the TX position. We've found that the discharge time of the first section to switch back to charge mode is stored in U9's latches. Therefore since TX changed first, the time is stored in the latches, and with U6B's Q output at zero the readout will display TX time when S4 is

set to TX. If you follow the sequence through, it will be found that U6B's Q output is zero when the RX section changes to charge mode first and we now have a means of selecting either display TX or display RX. A power on reset circuit made up of C1, R22, and U3D generates a short pulse each time AC power is applied. The reset ensures that the cyclor always starts in the charge mode and with a zero count on the time display. The multiplexing scheme is a standard scan system in which the seven segment display drive for each digit is present when its respective digit select (D1-D4) output goes high. Since all common segments (anode) in each individual display are tied together, with the seven outputs of U9 applied to all four digits at one time. The seven cathodes of each individual display digit are pulled to ground by one transistor, either Q11 to Q14, depending on which digits segments are being driven by U9 at that particular time. These transistors are driven by U9 in such a manner that the correct transistor is on when the correct segment information is being outputted for that particular digit. This allows four complete digits to be controlled by only eleven control lines rather than the conventional twenty-nine lines. The decimal points are also all common and Q9 provides drive at the proper time to light the tenth minute decimal point used in the application.

POWER SUPPLY:

The five volt power supply is a series regulator which uses a current boosted hybrid IC regulator. The IC is such that with no output from U1, into the five volt supply, U1 consumes only a few MA of supply current and since 2MA X 100 ohms is only 0.2 volts, this is not enough to turn on Q10. As the load on the five volt supply increases to approximately 4 MA, Q10 begins conducting and from this point on all additional five volt load current is supplied by Q10. U1 now only supplies Q10 with base drive current and varies this drive to maintain a precise five volt output.

III. PARTS LIST

CAPACITORS

- () 2 CE106PI 10 mf Electrolytic
- () 1 CE477PI 470 mf Electrolytic
- () 3 CD102 .001 mf Disc
- () 1 CD103 .01 mf Disc

SEMICONDUCTORS

- () 8 SS120 1N4001/4006 Diode
- () 3 SS121 1N4446 Diode
- () 1 SS125 1N746 Zener Diode
- () 2 SS075 Large Red LED
- () 2 SS075B Large Green LED
- () 1 SS110 Display Unit (MSB3881)
- () 2 SS000A MJE-170 Power Trans.
- () 2 SS000B MJE-180 Power Trans.
- () 4 SS033 2N4402 Transistors
- () 6 SS029 2N4400 Transistors

IC's

- () 1 SS041 LM340
- () 1 SS087A LM324A+
- () 2 SS084 CD4071
- () 2 SS088 CD4013
- () 1 SS085 CD4082
- () 1 SS089 CD4040
- () 1 SS086 74C926

RESISTORS All are 1/4W 5% unless specified.

- () 1 R0-680 68 ohm 2W (Bl, Gy, Bk)
- () 1 R0-241 240 ohm 2W (Rd, Ye, Br)
- () 1 R2-821 820 ohm 1/2W (Gy, Rd, Br)
- () 1 R4-470 47 ohm (Ye, Vi, Bk)
- () 2 R4-101 100 ohm (Br, Bk, Br)
- () 8 R4-201 200 ohm (Rd, Bk, Br)
- () 1 R4-301 300 ohm (Or, Bk, Br)
- () 5 R4-102 1K (Br, Bk, Rd)
- () 6 R4-202 2K (Rd, Bk, Rd)
- () 1 R4-512 5.1K (Gr, Br, Rd)
- () 5 R4-103 10K (Br, Bk, Or)
- () 5 R4-513 51K (Gr, Br, Or)
- () 1 R4-104 100K (Br, Bk, Ye)
- () 1 R4-105 1 Meg (Br, Bk, Gr)

- () 4 R4-51XB 5.1 ohm 1%*
- () 2 R4-302A 3K 2%*
- () 1 R4-752A 7.5K 2%*
- () 2 R4-153A 15K 2%*
- () 2 R4-433A 43K 2%*
- () 1 R4-861B 866 ohm 1%*
- () 1 R4-182B 1.87K 1%*
- () 1 R4-292B 2.94K 1%*
- () 2 R4-522B 5.23K 1%*
- () 1 R4-782B 7.87K 1%*
- () 1 R4-842B 8.45K 1%*
- () 2 10K Trim Pots

*These parts are identified on a separate sheet.

MISCELLANEOUS

- () 1 PC105 Digipace PC Board
- () 1 TT011 28V CT Transformer
- () 1 HW205 1/4A Fuse
- () 2 CC065 Fuse Clips
- () 2 SW015 CW DPDT Switch
- () 1 SW017 CW 3 Pos. Switch
- () 1 SW016 CW Momentary Sw.
- () 1 WW071 Line Cord
- () 1 PLA026 Dakaware Case
- () 1 LB054 Faceplate w/lens
- () 1 HW206 Wood Standoff
- () 1 HW139 Mica Insulator
- () 4 HW083B 4-40 X 3/8" Bolt
- () 4 HW002 4-40 Nut
- () 4 HW011E #4 Lockwasher
- () 1 HW113J #4 X 1/2" Self Tap
- () 4 HW090 6-32 X 1/4" Bolt
- () 2 RP003A #0 Grommet
- () 1 RP016 #3 Grommet
- () 36" Red and Black Wire
- () 36" Solder
- () 1 Capsule Heat Transfer Compound
- () 1 "120 ma" Sticker

IV. GENERAL CONSTRUCTION NOTES

- () Install and solder the parts on the board, following the suggested construction sequence. As you install a part, put a check mark in the ()'s provided on both the overlay drawings and the parts sheet. Observe the special instructions for individual components indicated on the parts sheets.
- () Bend the legs over sharply on the resistors that stand up and keep them tight on the board; this is so the top lead will not short out on the back of the aluminum faceplate when it is installed. Some 1% resistors may be oversized and have to be leaned over quite a bit to clear--no lead should be higher than 5/16" above the PC board.
- () Notice there are solder pads on both the bottom and the top of the PC board. The holes are not "plated through" so you must make all solder connections whether they are on the top or the bottom of the board!
- () Save about 20 of your scrap resistor leads that are cut off--they will be needed for the interconnects on the display unit.
- () The IC's are CMOS devices and should be kept in the foil package until installation. While handling them, be careful not to drop them on the floor or pick them up after shuffling across a carpet because they can be damaged by static electricity.

V. CONSTRUCTION SEQUENCE

- () 1. Install all IC's (U's) first. Make sure they are oriented properly and both top and bottom solder joints are made.
- () 2. Install resistors, capacitors, transistors, diodes and LED's on the front of the board starting from the center and fanning out to the edges. Insert a few parts in the board, solder, and clip the leads. Continue until all are in place.
- () 3. Solder in the four switches next.
- () 4. Install all the components on the back of the board.
- () 5. Install the display unit last.
- () 6. Closely inspect the board for good solder joints and that all joints have been made, both top and bottom. Make sure there are no solder bridges.
- () You will have either a 820ohm or a 68ohm resistor left over.

VI. FACEPLATE INSTALLATION

- () Mount the two No. 0 grommets for the output wires and the one No. 3 grommet in the faceplate--be careful not to scratch the aluminum.
- () Insert the line cord through the No. 3 grommet and pull it on through for about 6". A little saliva will ease the insertion.
- () Separate the line cord leads for about 1". Strip the insulation back 1/4" and tin the wire and solder to the PC board where shown. Make sure there are no frayed leads and that you have soldered to both the top and bottom of the board.
- () Snap the fuse into place.
- () Thread the red/black wire cables through the appropriate grommets and then pull on the line cord while holding the faceplate until it is in place over the PC board.
- () Line the faceplate up over the switches and LED's and move it into position--the switch levers should protrude through the holes in the faceplate and the LED's should engage in the grommets.
- () Smear silicon compound on the furnished Mica washer and with it between the metal portion of the transistor Q4 and the aluminum faceplate, bolt Q4 to the faceplate using a 4-40 X 3/8" bolt and nut. Tighten securely.
- () Hold the faceplate down on the switches and closely inspect for any bare leads shorting to the aluminum, especially the AC line cord! Correct if necessary.

VII. CHECKOUT & CALIBRATION

In order to check out the unit, you will need a charged transmitter (6, 9.6 or 12V) and receiver ni-cd battery pack, and a good digital or analog multi-meter.

CAUTION: There is 120V AC present on the PC board. Avoid getting shocked!

Making sure you maintain proper polarity, hook the receiver battery to the proper Digipace leads with the meter in series and set to a range that will include 50 ma. Set the charge rate switch to 20 ma or 120 ma (depending on the version you have built) and plug the unit in. The readout should indicate 000.0 and the charge LED on the receiver side should be lit. The meter should read approximately 20 or 120 ma. When the charge rate switch is moved to the 50 ma position, the meter should read approximately 50 ma.

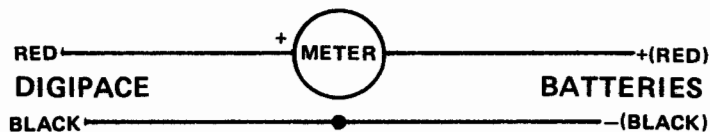

CHARGE CHECK

Unplug the unit and reverse the meter leads. Set the meter for a range that includes 300 ma. Plug the unit back in and begin the discharge cycle by moving the "Discharge Enable" to the left and release it. The charge LED should go out and the discharge LED should come on; the clock should be running. The meter should read 300 ma \pm 5 ma.

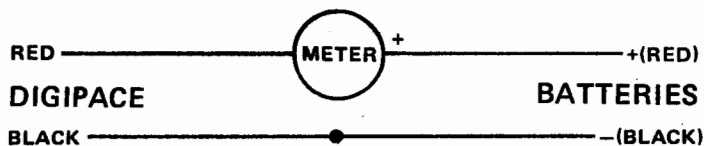

DISCHARGE CHECK

Repeat this procedure for the transmitter side of the Digipace, making sure the "Voltage Cutoff Level" switch is in the proper location for the transmitter pack you are using (5, 8, or 10 cell).

Trip voltage is the level at which the discharge cycle terminates and the charge cycle begins. It should be 1.1V per cell--4.4V for a 4.8V pack, 5.5V for a 6V pack, 8.8V for a 9.6V pack, and 11V for a 12V pack. This can vary 0.1V on either side and still give an accurate capacity reading. In order to check for proper trip voltage, hook up both battery packs to the Digipace and allow them to discharge, monitoring the voltage. This should take about 1½ hours, depending on the size of the packs.

Note at what voltage the unit trips into the charge cycle--if you miss it, let the batteries charge for 5 seconds or so and hit the Discharge Enable switch again, watching the voltmeter.

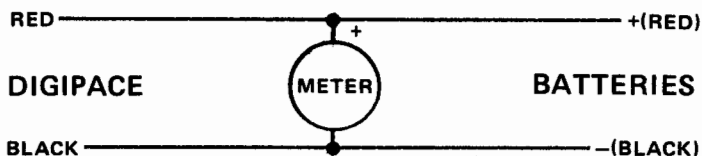

TRIP VOLTAGE CHECK

If the trip voltage varies more than $\pm 0.1V$, check the accuracy of your voltmeter first. If you're sure your instrument is accurate, it will be necessary to replace the precision resistors R3 for the transmitter side and R10 for the receiver side with the furnished 10K trimpots and then calibrate the pots for proper operation. To set the pots, refer to the parts overlay for

the back side of the board for pot location and rotate both pots fully clockwise as you face the back of the board. Working with one side at a time and monitoring voltage, discharge the battery pack to 0.1V below the desired cutoff voltage, then immediately rotate the appropriate pot counter-clockwise just until the unit goes into the charge cycle. Let the batteries charge a few seconds and check where the trip voltage is--it should be close. If necessary, continue repeating the procedure, adjusting the pot accordingly until the desired trip voltage is achieved.

This completes assembly and checkout of your Digipace. Install the unit in the black case furnished, securing the faceplate with four 6-32 X 1/4" screws.

VIII. TROUBLESHOOTING

If your Digipace fails to operate properly, first take a very close physical inspection--a magnifying glass is helpful. -Check all solder joints top and bottom; make sure you didn't miss any. -Make sure you have the right part in the right location. -Make sure all electrolytic capacitors, diodes, and transistors are oriented properly relative to their polarity or flat sides. -Make sure all IC's are positioned properly and not in backwards.

If you're sure that you have everything in right and everything is properly soldered, read the circuit description through a couple of times and study the schematic to familiarize yourself with the operation of the unit before trying to find the problem. Following are a few specific problems and their cures.

Again, double check that all joints on the top of the board have been soldered... there are over 100 of them!

DISPLAY:

No Display--Check fuse; check AC line; check to make sure the transformer is putting out 28V AC; check if there is regulated 5V--if not, check power supply components.

Segment Missing In Display--Look again for a bad joint or misplaced part in upper right 1/4 of the board. Could be bad Q11-Q14. RE-SOLDER JOINTS ON DISPLAY.

Only 2 left-hand digits lighted -- Component side solder connection open on Pin 7 U7.

Eights on display and works correctly -- No connection on 2 middle terminals of transformer output solder side (back of board).

Decimal points on all digits -- Check for 5V regulation (Go to power supply section).

Display lights w/connection to transmitter battery and unit unplugged -- CR1 no good or Q4 bad/wrong.

Decimal point doesn't light -- Check solder connections on Q9 and R38-R40.

CHARGING:

No transmitter charge current -- Check for 17V-20V on supply; CR1, VR1, or Q1 bad; wrong type for Q4.

Receiver charge current low -- Check for 17V-20V on supply; CR2 or Q2 bad; wrong value for R13 and R14.

Transmitter charge current too high -- Wrong or bad Q1.

If you still can't get the unit up and running, see the service policies in the "Kit Builder's Hints" for repair facilities and procedures.



BOX 511 116 W. 19TH ST. HIGGINSVILLE, MO. 64037

DISCHARGING:

- Discharge on one side only--check CR7 and CR8 for proper installation.
- Charge LED's stay on in discharge mode--check Q13, Q5, Q4.
- Receiver side discharges w/o hook-up - R10 open.
- Receiver side won't discharge - Check CR7 and U2.
- No discharge current - U2, Q4, or Q6 bad.
- Trip voltage too high - Check R3 and R10; install 10K trim pots for R3 and R10 and set trip voltages.
- R10 takes almost maximum travel to set trip voltage - R8 and R9 transposed.
- Won't go into discharge but discharge LED's light when pushing enable switch. - Trip voltages set too high; Batteries low. U2 bad.
- Won't discharge and discharge LED's don't light when pushing enable switch. - R2 and R22 shorted together.

TIMING:

- Display counting by two's and too fast - U8 bad.
- Counts w/o hook-up but not when hooked to batteries - CR3 bad.
- Readout status switch backwards - Component side solder connection open on Pin 11 U6.
- Readout status switch has no effect on display - check to make sure interboard jumper installed.
- No timing function out of U7 or U8 - Check CR6.
- Timing input to U9 but not counting - U9 bad.

POWER SUPPLY:

- 20V line too low; (17V - 20V normal - Check transformer for 28V AC; check CR4, CR5, RS2, and Q10.
- 20V line zero - Check C6 and VR1.
- 5V line too high - Check Q10, C4, U1, and C5.
- 5V line zero - Check U1.
- No 120V AC to transformer - Check fuse, check solder connection on line cord and fuse clips.

LED's don't light--Check to see if they are installed backwards or physically broken. Charge/discharge functions will operate if LED's are bad.

Reverse polarity has been applied--Replace U2. Check R16, R17, R19, R20, Q4, Q6.

PARTS IDENTIFIER SHEET

Integrated Circuits (U's)

Make sure all of them are installed with the notches and/or dots in the orientation indicated on the overlay drawing. Solder both top and bottom where necessary!

- () U1-LM340
Mount with the flat side as shown.
- () U2-LM324
- () U3-CD4071
- () U4-CD4013
- () U5-CD4071
- () U6-CD4013
- () U7-CD4082
- () U8-CD4040
- () U9-74C926

Transistors (Q's)

Install all 2N4400 and 2N4402's with the flat side as indicated in the overlay. Keep the bottoms of these transistors about 1/8" above the board.
Bend the legs of two MJE-170's and one MJE-180 down as shown and the legs of the other MJE-180 up as shown using a needle nose pliers.

When installing Q1, Q6, and Q10, smear a small amount of silicone heat transfer compound (furnished in a pill capsule) on the metal portion of the transistor body and bolt the transistors to the board with a 4-40 x 3/8" bolt, nut and lock-washer. Q4 will be bolted to the faceplate later with a mica washer between it and the faceplate.

- () Q1-MJE-170
- () Q2-2N4402
- () Q3-2N4400
- () Q4-MJE-180
- () Q5-2N4400
- () Q6-MJE-180
- () Q7-2N4402
- () Q8-2N4402
- () Q9-2N4402
- () Q10-MJE-170
- () Q11-2N4400
- () Q12-2N4400
- () Q13-2N4400
- () Q14-2N4400

Capacitors (C's)

Make sure the polarity matches the overlay on the electrolytic capacitors.

- () C1-10 mf Electrolytic
- () C2-1001 mf Disc
- () C3-1001 mf Disc
- () C4-1001 mf Disc
- () C5-10 mf Electrolytic
- () C6-470 mf Electrolytic
- () C7-.01 mf Disc

Resistors (R's)

All resistors are 1/4W and 5% unless specified. Find 1% and 2% resistors on ID sheet.

- () R1-15K 2% (On ID sheet)
- () R2-3K 2% (On ID sheet)
- () R3-5.23K 1% (On ID sheet)
- () R4-7.5K 2% (On ID sheet)
- () R5-100 ohm (Brown, black, brown)
- () R6-1.87K 1% (On ID sheet)
- () R7-47 ohm (Yellow, violet, black)
- () R8-15K 2% (On ID sheet)
- () R9-3K 2% (On ID sheet)
- () R10-5.23K 1% (On ID sheet)
- () R11-966 ohm 1% (On ID sheet)
- () R12-2K (Red, Black, Red)
- () R13-240 ohm 2W (Red, Yellow, Brown)
- () R14-2K (Red, Black, Red)
- () R15-2K (Red, Black, Red)
- () R16-5.1 ohm 1% (On ID sheet)
- () R17-5.1 ohm 1% (On ID sheet)
- () R18-10K (Brown, Black, Orange)
- () R19-5.1 ohm 1% (On ID sheet)
- () R20-5.1 ohm 1% (On ID sheet)
- () R21-51K (Green, Brown, Orange)
- () R22-100K (Green, Brown, Yellow)
- () R23-51K (Green, Brown, Orange)
- () R24-51K (Green, Brown, Orange)
- () R25-43K 2% (On ID sheet)
- () R26-7.87K 1% (On ID sheet)
- () R27-43K 2% (On ID sheet)
- () R28-8.45K 1% (On ID sheet)

Make sure the top lead will not short to face plate.
See calibration text.
A 10K pot may be substituted - See calibration text.
Make sure the top lead will not short to face plate.

- () R29-51K (Green, Brown, Orange)
- () R30-1K (Brown, Black, Red)
- () R31-10K (Brown, Black, Orange)
- () R32-10K (Brown, Black, Orange)
- () R33-10K (Brown, Black, Orange)
- () R34-10K (Brown, Black, Orange)
- () R35-10K (Brown, Black, Orange)
- () R36-1M (Brown, Black, Green)
- () R37-51K (Green, Brown, Orange)
- () R38-300 ohm (Orange, Black, Brown)
- () R39-200 ohm (Red, Black, Brown)
- () R40-1K (Brown, Black, Red)
- () R41-200 ohm (Red, Black, Brown)
- () R42-200 ohm (Red, Black, Brown)
- () R43-200 ohm (Red, Black, Brown)
- () R44-200 ohm (Red, Black, Brown)
- () R45-200 ohm (Red, Black, Brown)
- () R46-200 ohm (Red, Black, Brown)
- () R47-200 ohm (Red, Black, Brown)
- () R48-2K (Red, Black, Red)
- () R49-2K (Red, Black, Red)
- () R50-2K (Red, Black, Red)
- () R51-2K (Red, Black, Red)
- () R52-100 ohm (Brown, Black, Brown)
- () R53-2.94K 1% (On ID sheet)
- () R54-5.1K (Green, Brown, Red)
- () R55-1K (Brown, Black, Red)
- () R56-1K (Brown, Black, Red)
- () R57-1K (Brown, Black, Red)

Make sure the top lead won't short to faceplate.
Make sure top lead won't short to faceplate.

Diodes (CR's)

The following diodes are 1N4001/1N4006. Install with banded end (cathode) as indicated.

- () CR1-Banded End Down
- () CR2-Banded End Up
- () CR3-Banded End Up
- () CR4-Banded End as Shown
- () CR5-Banded End Down
- () CR6-Banded End Down
- () CR7-Banded End Up
- () CR8-Banded End Up

The following diodes are 1N4446. Install with banded end (cathode) as indicated.

- () CR7-No holes are provided for this diode. Bend, cut and solder the leads as illustrated, making sure the banded ends are oriented properly and the exposed leads don't short out to any other connections.
- () CR8-Same as above.
- () CR11-Banded End as Shown

Zener Diode (VR)

- () VR1-1N746 Install with banded end up.

Displays (DS's)

Solder the LED's in so they stand up straight and the bottom of the plastic body is 3/16" from the PC board.

- () DS1-Green LED; Cathode to the left.
- () DS2-Green LED; Cathode to the left.
- () DS3-Red LED; Cathode to the right.
- () DS4-Red LED; Cathode to the right.

Cover the plastic face of the digital display (DS5) with masking tape while soldering in order to prevent damage from splattering solder. Remove the paper backing from the double sided tape on the rear of the display unit and stick it to the Digipace PC board so the holes line up.
Insert scrap resistor leads through the holes and solder them to the top of the display unit and the bottom of the Digipace PC board. Make sure you don't miss any. Remove the tape from the display.

- () DS6-Display Unit NSB3881

Switches (S's)

Make sure the switches are down as close to the board as they will go and that they remain straight up and down.

- () S1-Three Position Switch (DPST)
- () S2-DPDT Slide Switch
- () S3-SPDT Momentary Switch
- () S4-DPDT Slide Switch

There's a joint on the top of the board that's easy to miss!

Miscellaneous

- () T1-28V CT Transformer
- Make sure all enamel is scraped off where soldering is done.

FUSE CLIPS

Solder to back of the board as shown. Make sure the "crimped" ends of the clips are on the outboard side so the fuse can be installed properly.

- () FUSE-AGC% Do not install yet.

WIRE-Solder 18" of red and black hookup wire as indicated on the parts overlay. Twist each red and black together, making two pairs. Tie a knot in each pair about 1/2" from the PC board for strain relief.

JUMPER-Solder a scrap resistor lead in the position indicated on the parts overlay on both the top and the bottom of the board. It electrically connects a top land with a bottom land.

- () STANDOFF-Secure the wood standoff in place with a No. 4 X 1/2 self tap screw.

***You have a choice to make. The lower position of the Receiver Charge Rate Switch can be programmed to produce either 20ma for small 100-250mah battery packs or 120ma for large 900-1500mah packs. For R-14, install a 820ohm 1/2W (Grey, Red, Brown) for the 20ma charge rate; use the 68ohm 2W (Blue, Grey, Black) for the 120ma rate. A sticker that says "120ma" is provided to apply over the "20ma" on the faceplate.**

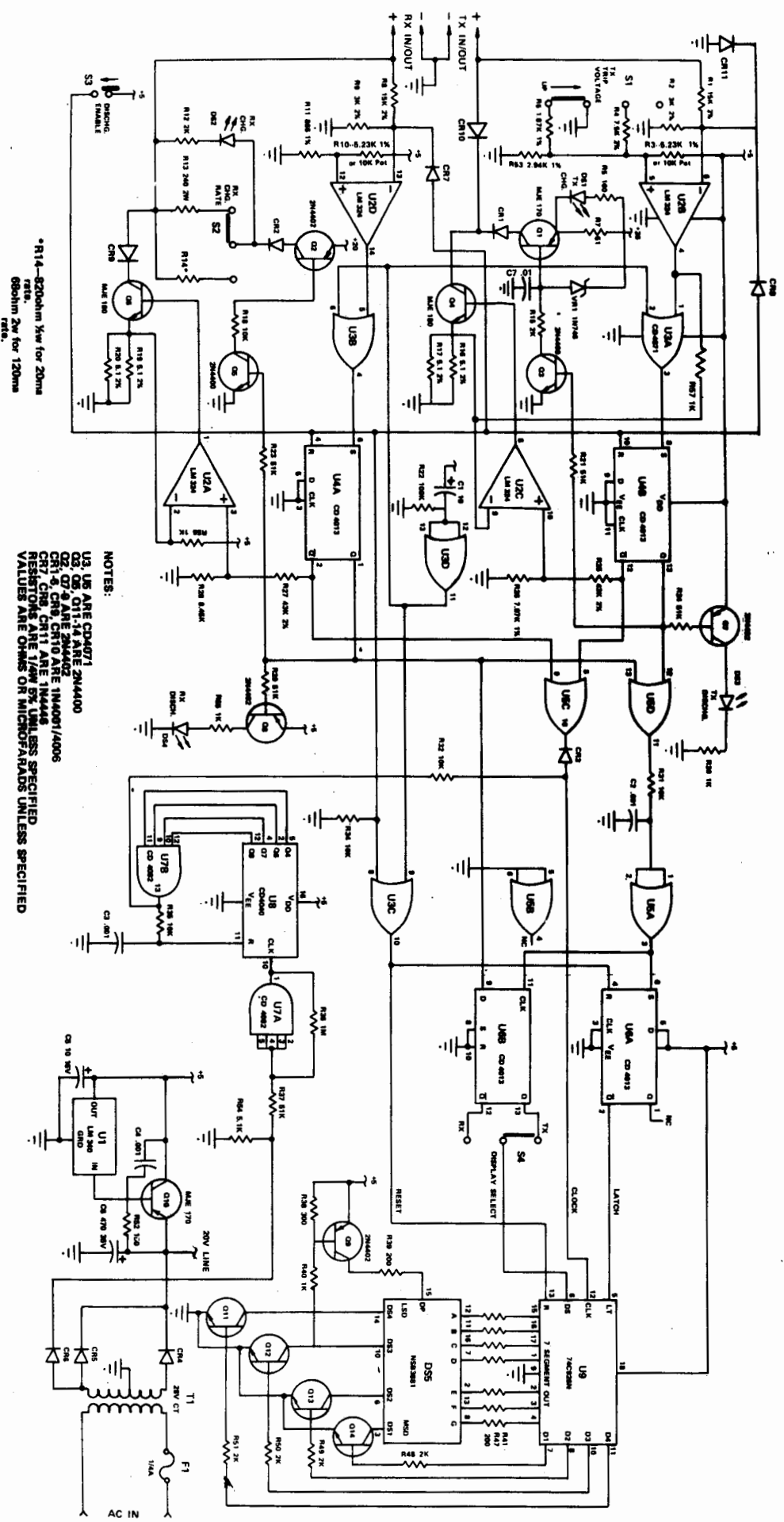

SCHEMATIC

*R14-820ohm 1/4w for 20ma
 ref.
 820ohm 2w for 120ma
 ref.

NOTES:

- U3, U5 ARE CD4071
- U2, U6, U7, U8, U9 ARE 7490
- U10, U11, U12, U13, U14, U15, U16, U17, U18, U19, U20, U21, U22, U23, U24, U25, U26, U27, U28, U29, U30, U31, U32, U33, U34, U35, U36, U37, U38, U39, U40, U41, U42, U43, U44, U45, U46, U47, U48, U49, U50, U51, U52, U53, U54, U55, U56, U57, U58, U59, U60, U61, U62, U63, U64, U65, U66, U67, U68, U69, U70, U71, U72, U73, U74, U75, U76, U77, U78, U79, U80, U81, U82, U83, U84, U85, U86, U87, U88, U89, U90, U91, U92, U93, U94, U95, U96, U97, U98, U99, U100 ARE 7410-7499
- RESISTORS ARE 1/4W EX UNLESS SPECIFIED
- VALUES ARE OHMS OR MICROFARADS UNLESS SPECIFIED

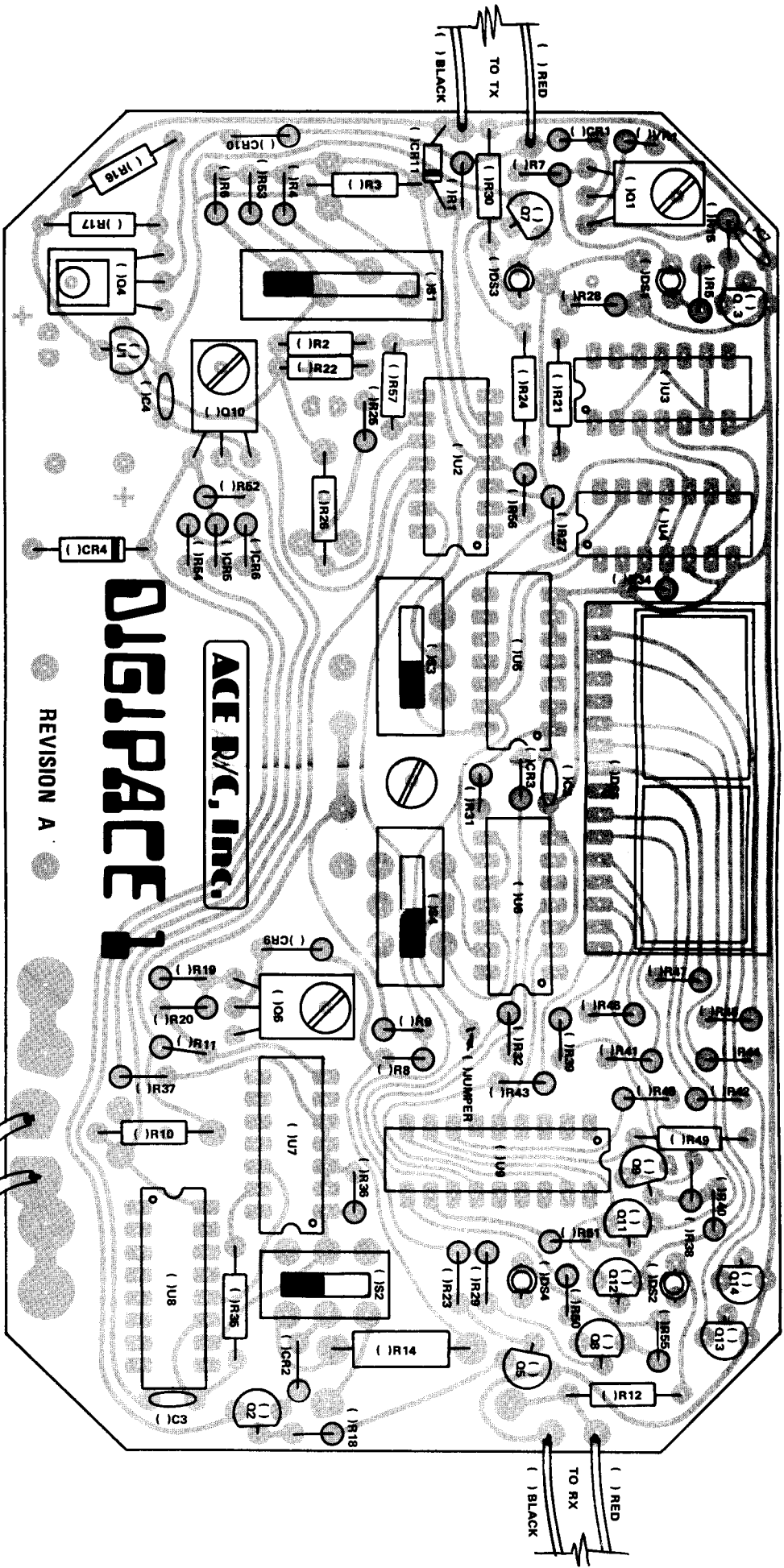

REVISION A

DIGIPACE 1
ACE P/C, Inc.

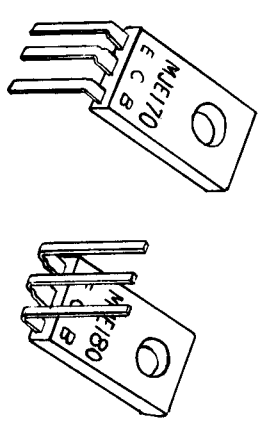

BEND LEGS DOWN ON TWO
 MJE170S AND ONE MJE180.
 BEND LEGS UP ON ONE MJE180

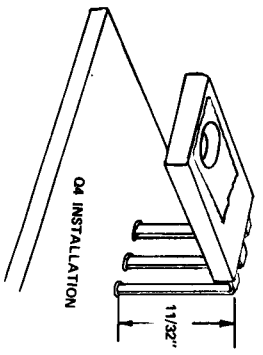

Q4 INSTALLATION

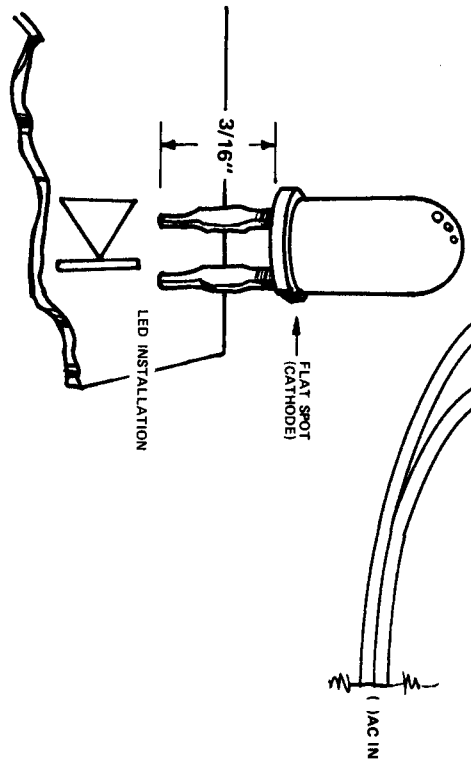

LED INSTALLATION

FLAT SPOT
 (CATHODE)

() RED
 TO RX
 () BLACK

() RED
 TO TX
 () BLACK

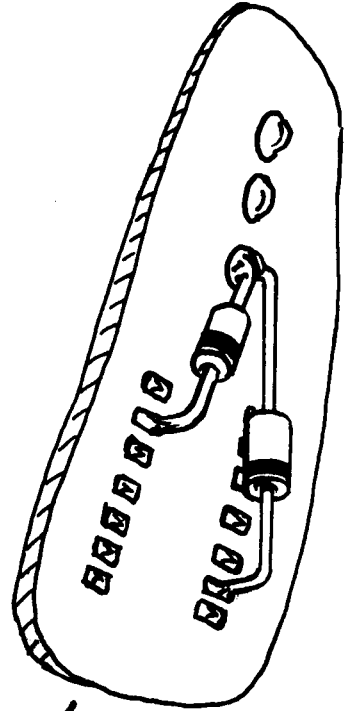
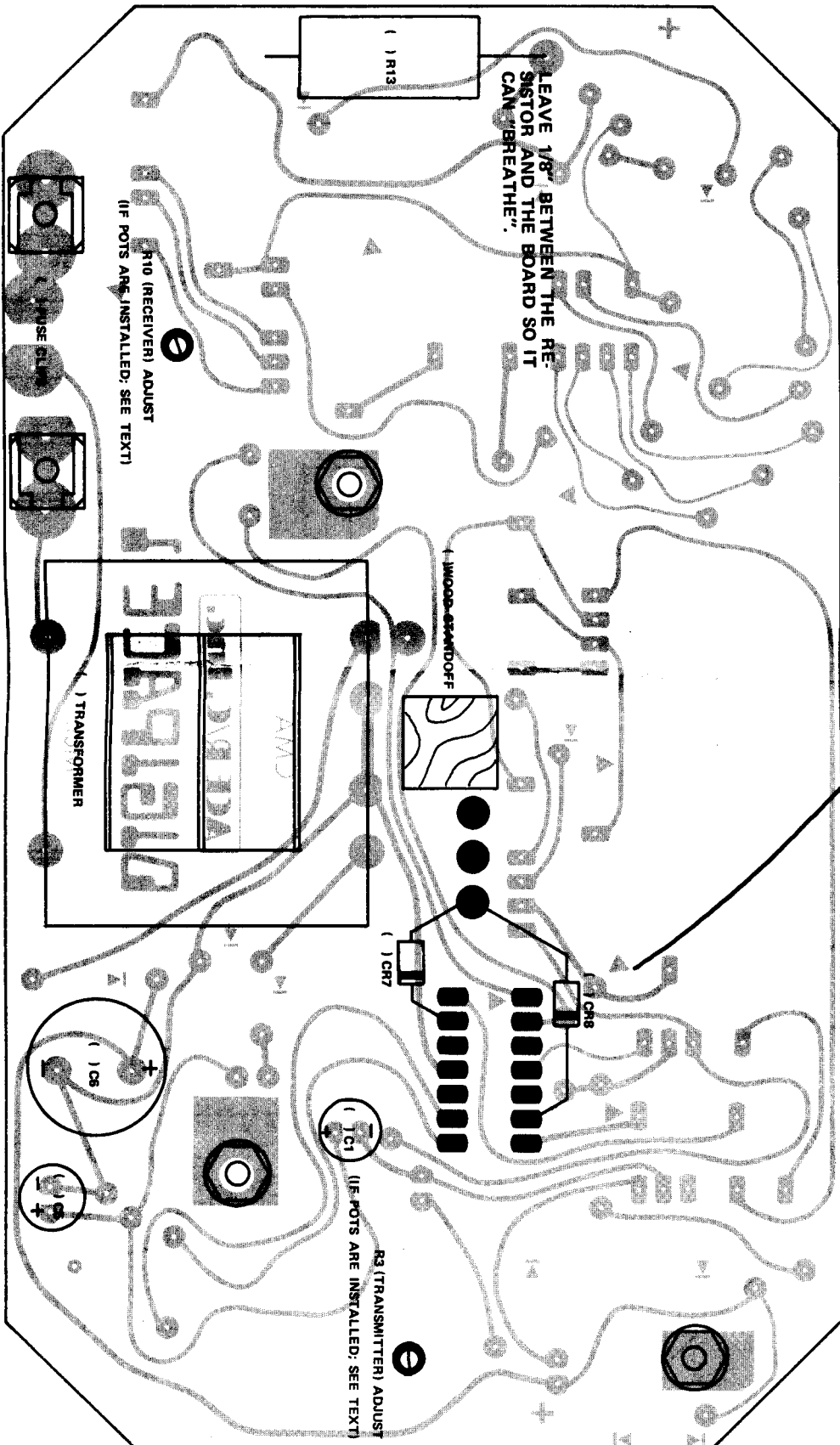

BACK OF BOARD

LEAVE 1/8" BETWEEN THE RESISTOR AND THE BOARD SO IT CAN "BREATHE".

R10 (RECEIVER) ADJUST
(IF POTS ARE INSTALLED: SEE TEXT)

R3 (TRANSMITTER) ADJUST
(IF POTS ARE INSTALLED: SEE TEXT)

TRANSFORMER

AMD

(1) CR7

(1) CR8

(1) IC1

(1) C6

(1) R13

WOOD STANDOFF